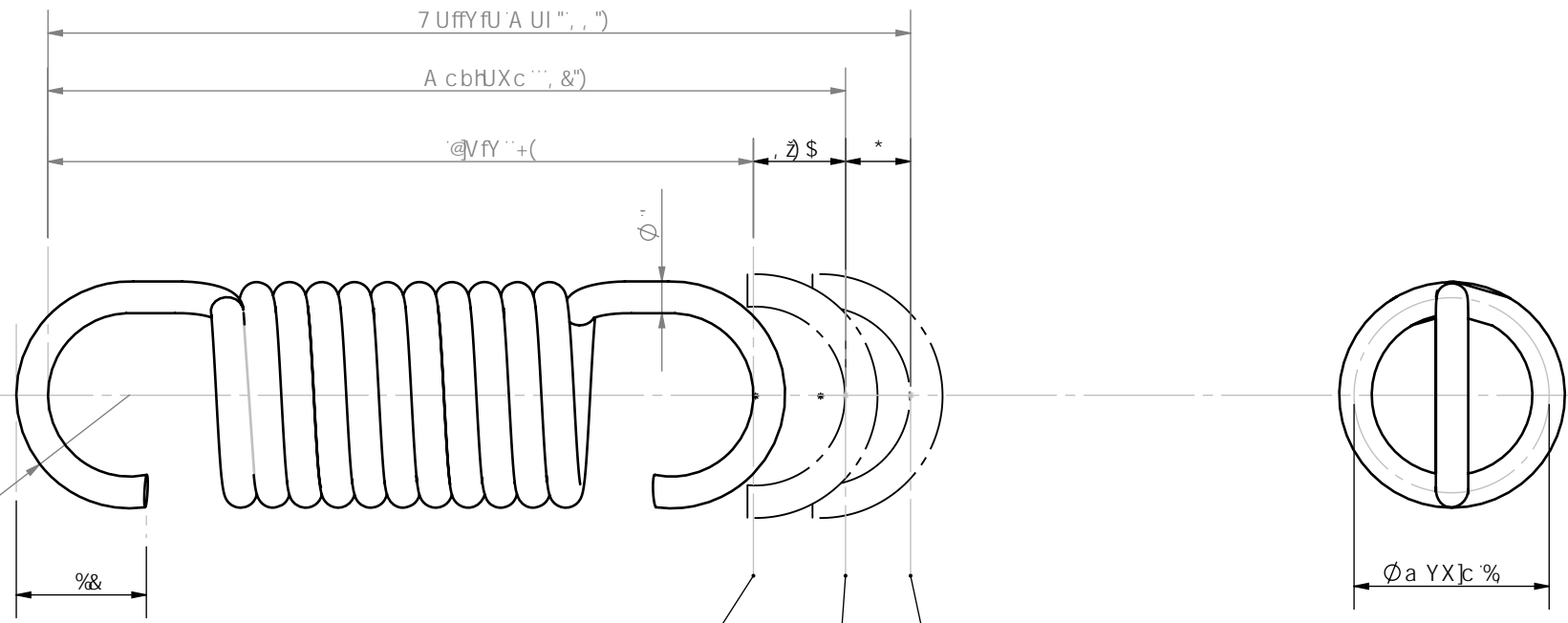

Hc YfubWJugdJ c YgdYVWZMUWJCb
>G% 1 'g% 'F5A ') \$\$&

Gja Vc'cgXY 'UVfUXc
#5A ') %+

ž & ? [# a a &
%+ž\$) ? [# a a &
&(ž' ±&' ? [# a a &
* &ž) ? [# a a &

7 Ubh'dcfWcWY. %*
@Jga YX]XUgYgzb Yl dfYgJXUgYb'a]]a Yhfcg

9a "V. gY 'WUa V]EbfC"XY'd'Ubc'fUbhYgYfU '&+%\$&8HA F\$\$' , E"
..... \$, # \$' #&\$%\$

7 URUVWYfgjWUg	Hc YfubWJug
8]Ua Yhfc 'XY'U'Ua Vfy'Qa a Q	± \$Z%
8]Ua Yhfc '9l hYfbc'Qa a Q	± \$Z%
B °XY '9gd]fUg	%%
: YI]]XUX'Qa a #[fQ	\$ž+*)
Gybh]Xc 'XY'Uffc'Ua]Ybhc	8YfYVWc
7 Uf] U'XY'di YVU'Q' [Q	&(ž-

#PA	8 9G7 F-Đ7 € B	7 5BH'	G5 9%\$+\$	\$- (6!) ' %' ' (&' '\$	&+\$%\$&%- -- \$
: YWU.	% ! \$' !&\$\$,		A 5HPF-5@	F:	BI A
8-6l >C	7 "J U'XYg			NRP GC I TCNOTQEC WI QHG'UCO	D- FB7DE &+\$%\$&8HA F\$\$' -
F9J -€C	F"A cfc b]				KJ 7B7S Ha cbYf]U' XY'ZYbc '7 7 FF
5DFC 6C	F"NUFU				QHIERP'VGEP'EC 5(O CVGTICN'TQF'CPVG
9A -€C B	9gWU U Gf9gW	HH @C			
U X V			FYgc fhY 'FYhc fbc 'XY'NUdUHU		
W X	HfcWU U				
Y Z	%*+*				



República Argentina - Poder Ejecutivo Nacional
2019 - Año de la Exportación

**Hoja Adicional de Firmas
Pliego Especificaciones Tecnicas**

Número:

Referencia: PLIET - 270102DTMR0039 - RESORTE DE REENVIO

El documento fue importado por el sistema GEDO con un total de 1 pagina/s.