

TRENES ARGENTINOS OPERACIONES

DOCUMENTACIÓN TÉCNICA PARA COMPRA

NUM43360810320N

Descripción: Conector macho aéreo, 8 polos + 12x5 polos, sección 0,14-2,5mm², salida recta M40. Conector para cable de entre coches XSP91. Fichas y terminales. Cables y accesorios. Sistema colector y distribución. CCEE CSR.

Plano N°: No Corresponde

Planos concatenados N°: No Corresponde

Referencia de fábrica: (Descrito en hoja 2)

Especificación Técnica: ET MRR/G-007, última emisión.

Norma de aplicación: No Corresponde

Inserto contacto Macho para conectores de entre coche XSP91.

Función:

	ELABORÓ	REVISÓ	APROBÓ
NOMBRE	G. Barborini	Ing. H. Baigorria	Ing. C. Valdes Lazo
FIRMA	-	-	-



CONFORMADO POR:

- RF: 09 14 012 3001 - Cantidad 5 (Harting)
- RF: 09 15 000 6101 - Cantidad 56 (Harting)
- RF: 09 14 008 3001 - Cantidad 1 (Harting)
- RF: 09 15 000 6102 - Cantidad 8 (Harting)
- RF: 09 14 024 0303 - Cantidad 1 (Harting)
- RF: 19 40 024 0413 - Cantidad 1 (Harting)

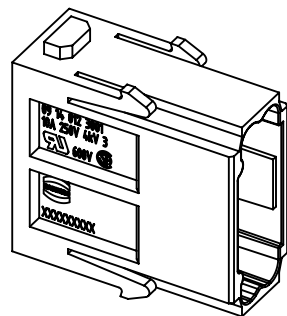
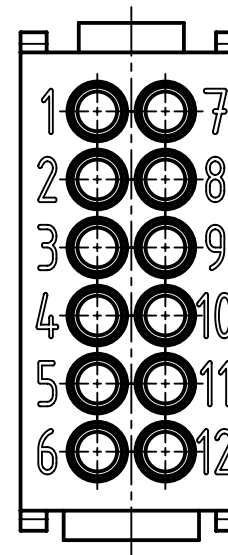
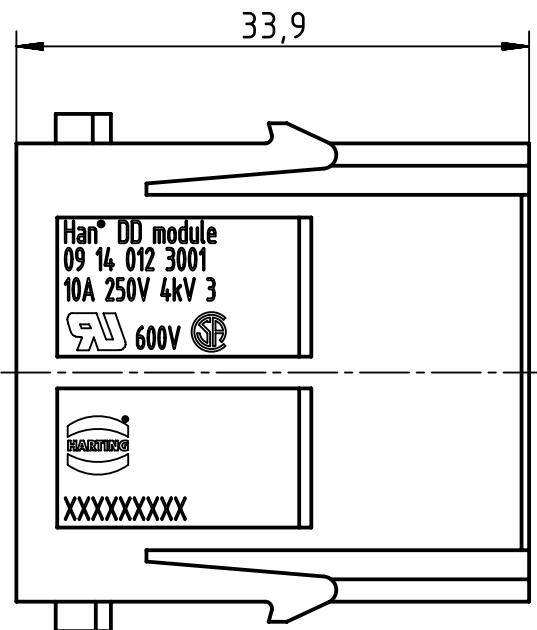
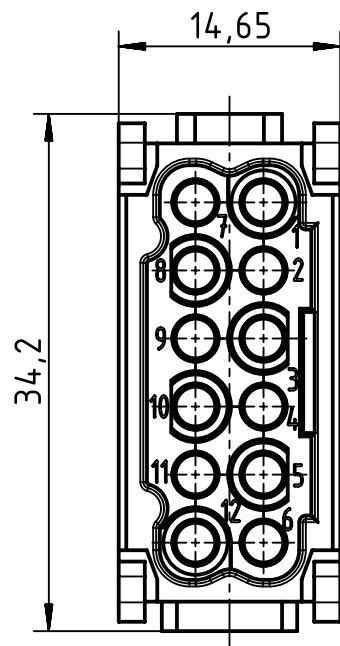

	All Dimensions in mm Original Size DIN A4		Scale 2:1	Free size tol.		Ref. Sub. TB 09 14 012 3001 v. 03.11.94		
		All rights reserved Department EL PD - DE	Created by RULLKOETTER	Inspected by SCHNIEDER	Standardisation RUETERA	Date 2015-08-10	State Final Release	
HARTING Electric GmbH & Co. KG D-32339 Espelkamp		Title Han DD module, crimp male				Doc-Key / ECM-Nr. 100518533/UGD/001/C 500000091604		
			Type TB	Number 09 14 012 3001			Rev. C	Page 1/1

A

B

C

D

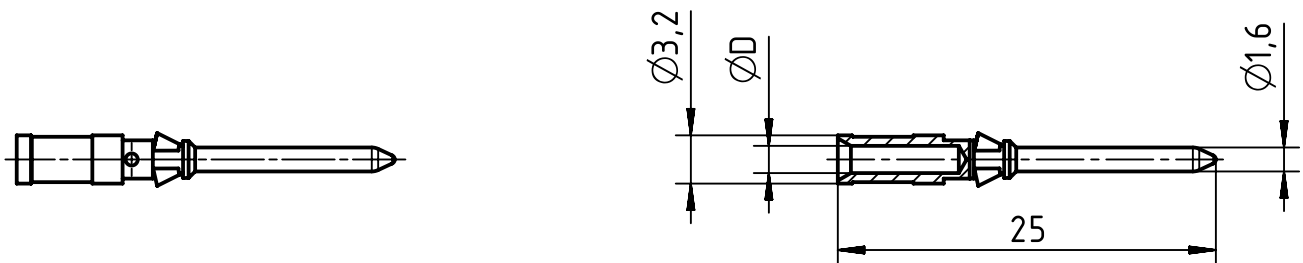

① only for four indent crimping tool adjusting Ø0,1

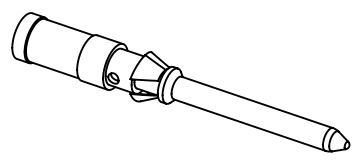

part no.		ØD	wire gauge		stripping length	
silver plated	gold plated		mm²	AWG		
09 15 000 6104	09 15 000 6124	0,90	0,14-0,37	26-22	8	
09 15 000 6103	09 15 000 6123	1,10	0,5	20		
09 15 000 6105	09 15 000 6125	1,30	0,75	18		
09 15 000 6102	09 15 000 6122	1,45	1	18		
09 15 000 6101	09 15 000 6121	1,75	1,5	16		
09 15 000 6106	09 15 000 6126	2,25	2,5	14	6	
09 15 000 6107	09 15 000 6127	0,90	0,14-0,37	26-22	8	①

	All rights reserved		Scale 2:1	Free size tol.	Ref. Sub. TB 09 15 000 61. v. 22.03.99	
	Department EL PD - DE		Created by RULLKOETTER	Inspected by SCHNIEDER	Standardisation TIEMANNA	Date 2014-05-20
HARTING Electric GmbH & Co. KG D-32339 Espelkamp			Title Han D crimp contacts male			Doc-Key / ECM-Nr. 100086611/UGD/006/A 500000075030
Type TB		Number 09 15 000 61XX		Rev. A	Page 1/1	

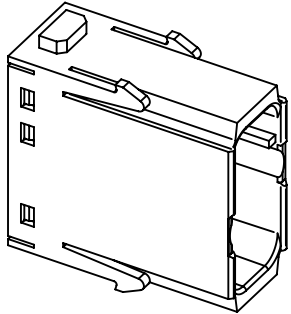
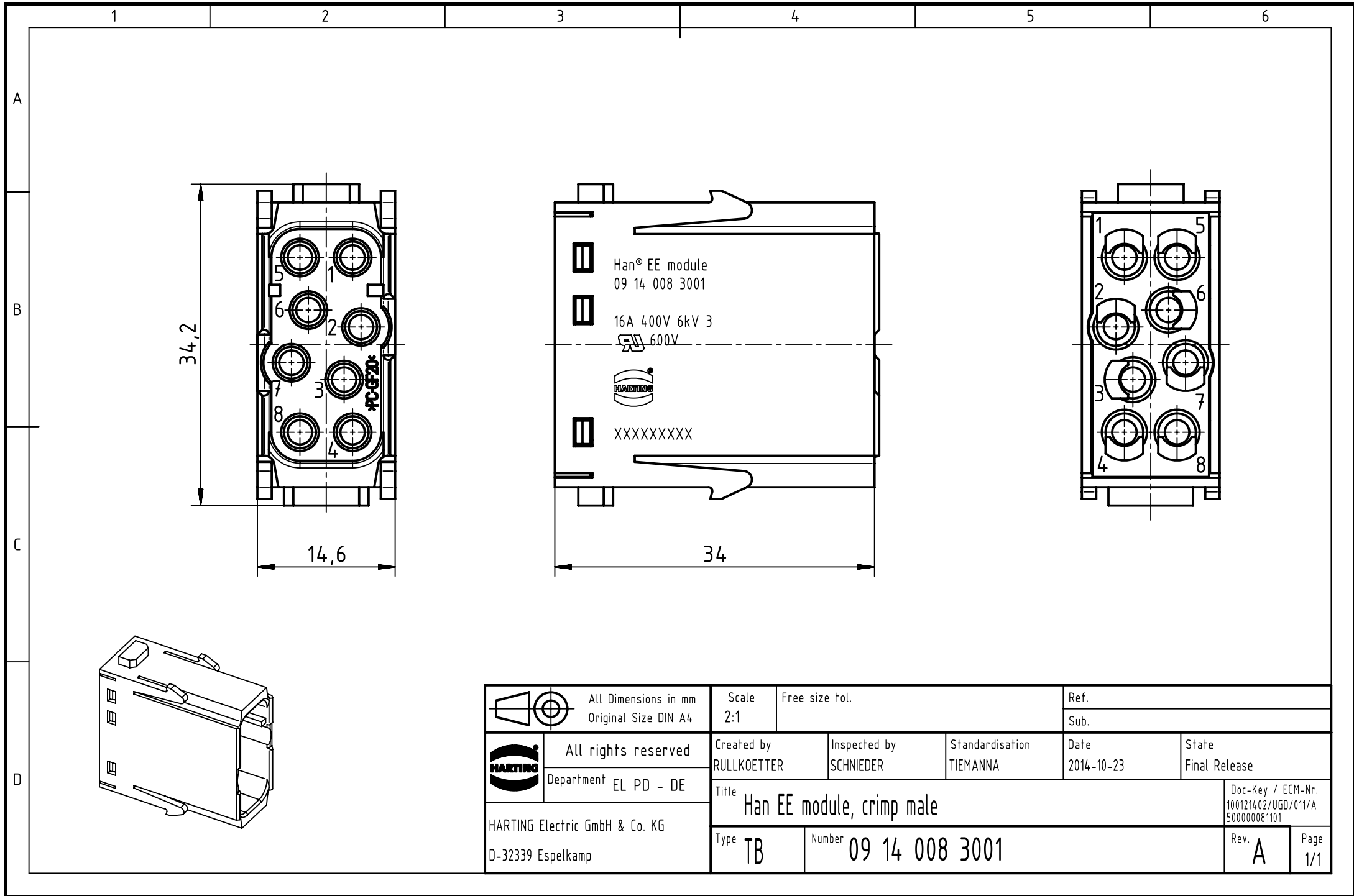

	All Dimensions in mm Original Size DIN A4	Scale	Free size tol.		Ref.	
		2:1			Sub.	
	All rights reserved Department EL PD - DE	Created by	Inspected by	Standardisation	Date	State
		RULLKOETTER	SCHNIEDER	TIEMANNA	2014-10-23	Final Release
HARTING Electric GmbH & Co. KG D-32339 Espelkamp		Title			Doc-Key / ECM-Nr.	
		Han EE module, crimp male			1001214-02/UGD/011/A 500000081101	
		Type	Number	Rev.	Page	
		TB	09 14 008 3001	A	1/1	

A

B

C

D

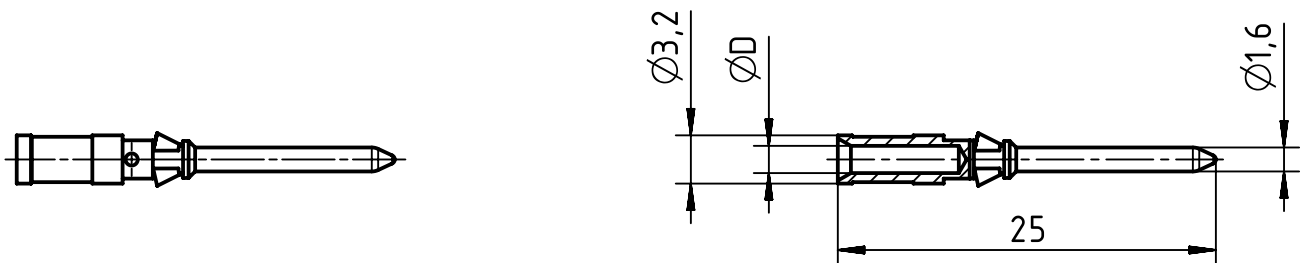

① only for four indent crimping tool adjusting Ø0,1

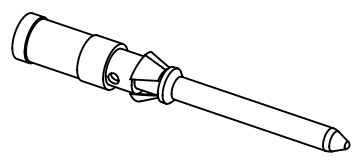

part no.		ØD	wire gauge		stripping length	
silver plated	gold plated		mm²	AWG		
09 15 000 6104	09 15 000 6124	0,90	0,14-0,37	26-22	8	
09 15 000 6103	09 15 000 6123	1,10	0,5	20		
09 15 000 6105	09 15 000 6125	1,30	0,75	18		
09 15 000 6102	09 15 000 6122	1,45	1	18		
09 15 000 6101	09 15 000 6121	1,75	1,5	16		
09 15 000 6106	09 15 000 6126	2,25	2,5	14	6	
09 15 000 6107	09 15 000 6127	0,90	0,14-0,37	26-22	8	①

	All rights reserved		Scale 2:1	Free size tol.		Ref.		
	Department EL PD - DE		Created by RULLKOETTER	Inspected by SCHNIEDER	Standardisation TIEMANNA	Date 2014-05-20	State Final Release	
HARTING Electric GmbH & Co. KG		Title Han D crimp contacts male					Doc-Key / ECM-Nr. 100086611/UGD/006/A 500000075030	
D-32339 Espelkamp		Type TB	Number 09 15 000 61XX			Rev. A	Page 1/1	

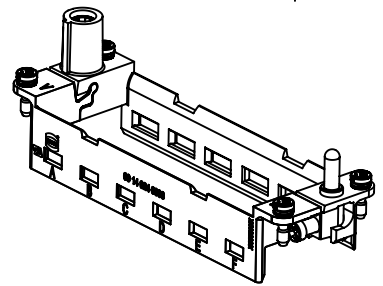
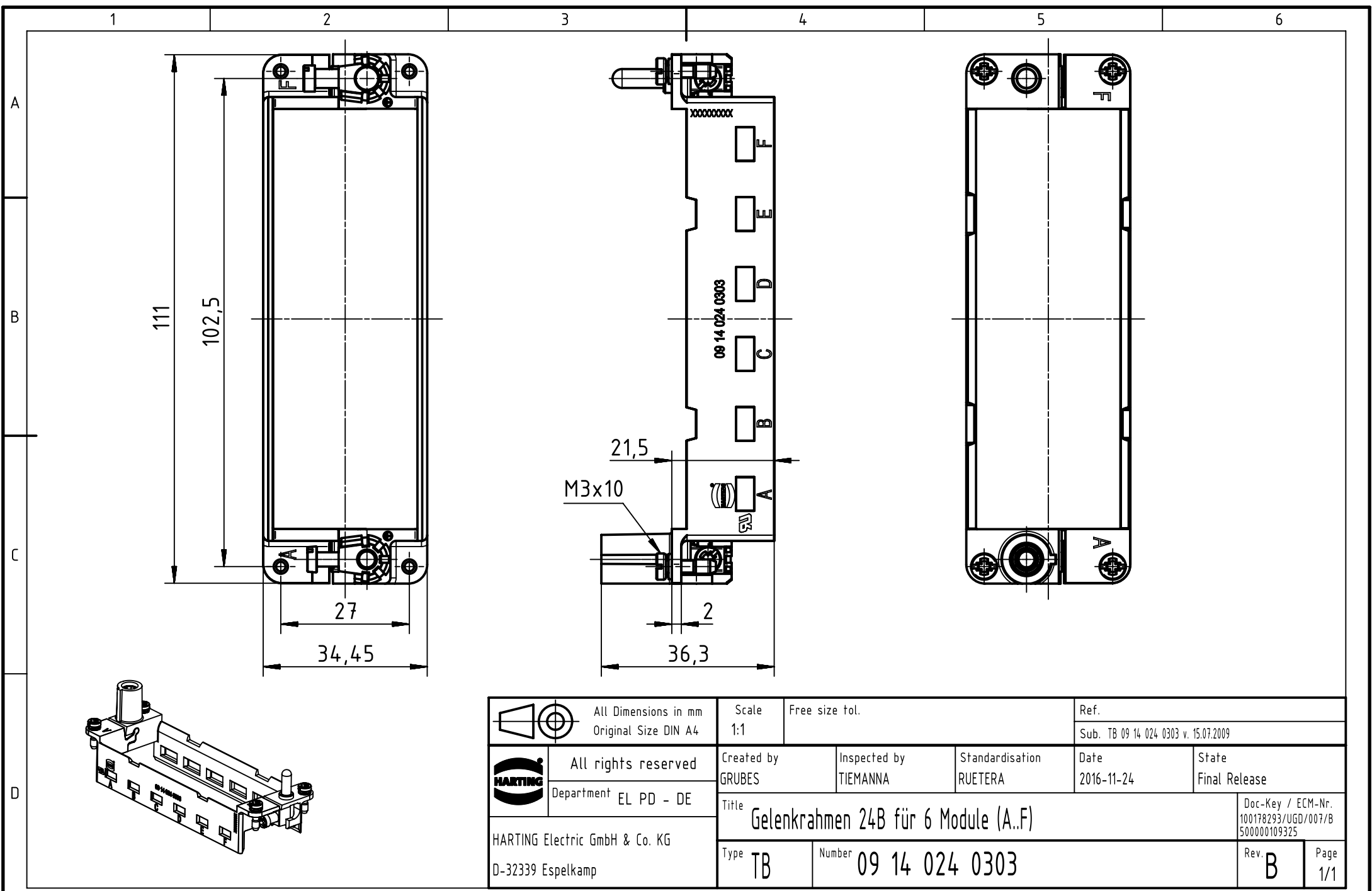

	All Dimensions in mm Original Size DIN A4		Scale 1:1	Free size tol.		Ref. Sub. TB 09 14 024 0303 v. 15.07.2009		
		All rights reserved Department EL PD - DE		Created by GRUBES	Inspected by TIEMANNA	Standardisation RUETERA	Date 2016-11-24	State Final Release
HARTING Electric GmbH & Co. KG D-32339 Espelkamp				Title Gelenkrahmen 24B für 6 Module (A..F)			Doc-Key / ECM-Nr. 100178293/UGD/007/B 500000109325	
				Type TB	Number 09 14 024 0303		Rev. B	Page 1/1

1 2 3 4 5 6

X (2:1)

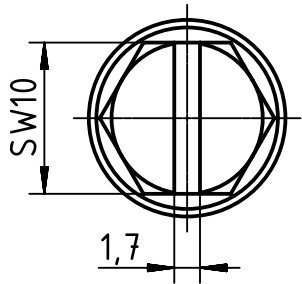

M 40x1,5

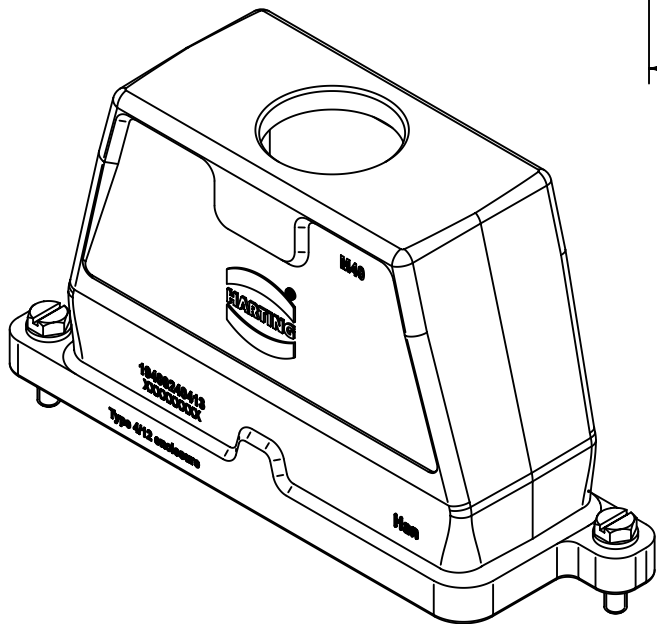
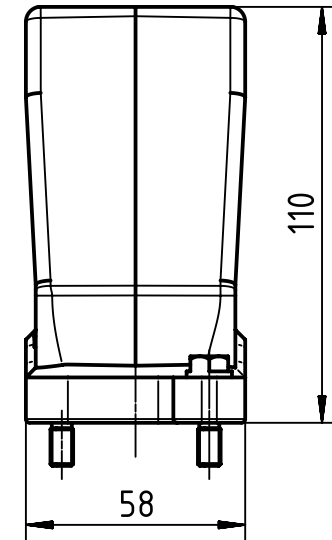
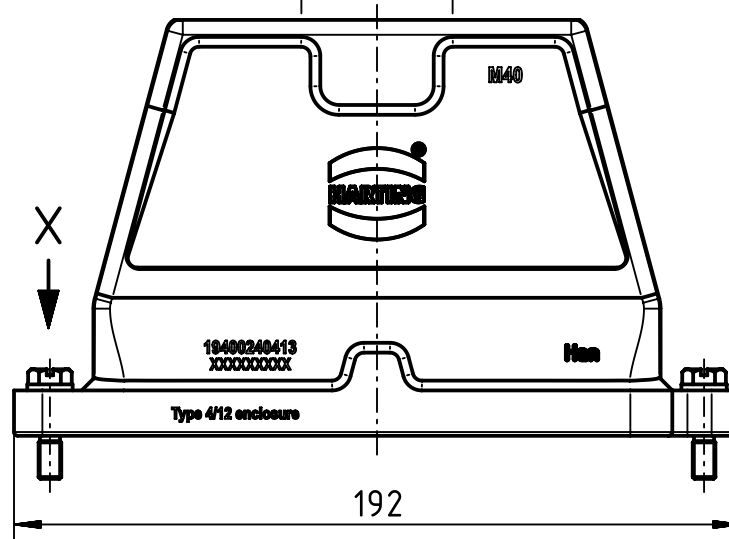

	All Dimensions in mm Original Size DIN A4	Scale 1:2			Free size tol.		Ref.	
							Sub. TB 19 40 024 0413 v. 10.01.11	
	All rights reserved Department EL PD - DE	Created by	Inspected by	Standardisation	Date	State		
		FINKEV	GERB	TIEMANNA	2015-11-13	Final Release		
HARTING Electric GmbH & Co. KG D-32339 Espelkamp		Title Han 24 HPR Hood Top Entry M40 Screw Lock				Doc-Key / ECM-Nr. 10020194.9/UGD/004/B 500000094.164		
		Type TB	Number 19 40 024 0413			Rev. B	Page 1/1	

TRENES ARGENTINOS OPERACIONES

DOCUMENTACIÓN TÉCNICA PARA COMPRA

NUM43360810330N

Descripción: Conector p/chasis, hembra, 8 polos + 12x5 polos, sección 0,14-2,5mm². Conector para cable de entre coches XSP92. Fichas y terminales. Cables y accesorios. Sistema colector y distribución. CCEE CSR.

Plano N°: No Corresponde

Planos concatenados N°: No Corresponde

Referencia de fábrica: (Descrito en hoja 2)

Especificación Técnica: ET MRR/G-007, última emisión.

Norma de aplicación: No Corresponde

Inserto contacto Hembra para
conectores de entre coche
XSP92.

Función:

	ELABORÓ	REVISÓ	APROBÓ
NOMBRE	G. Barborini	Ing. H. Baigorria	Ing. C. Valdes Lazo
FIRMA	-	-	-



CONFORMADO POR:

- RF: 09 14 012 3101 - Cantidad 5 (Harting)
- RF: 09 15 000 6201 - Cantidad 56 (Harting)
- RF: 09 14 008 3101 - Cantidad 1 (Harting)
- RF: 09 15 000 6202 - Cantidad 8 (Harting)
- RF: 09 14 024 0313 - Cantidad 1 (Harting)
- RF: 09 40 024 0311 - Cantidad 1 (Harting)

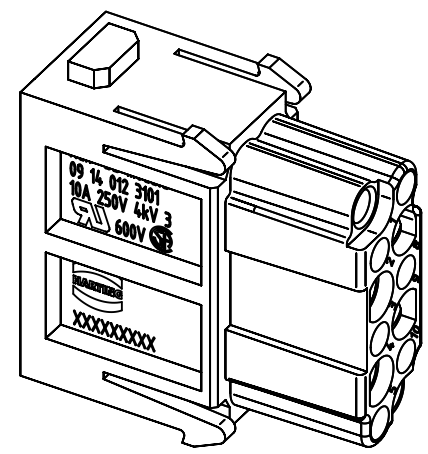
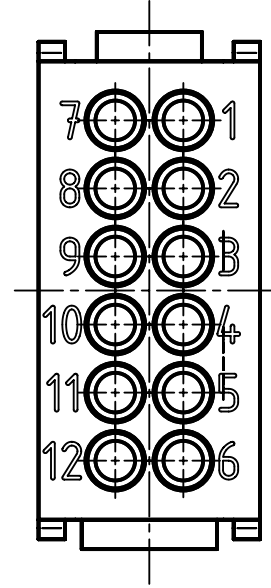
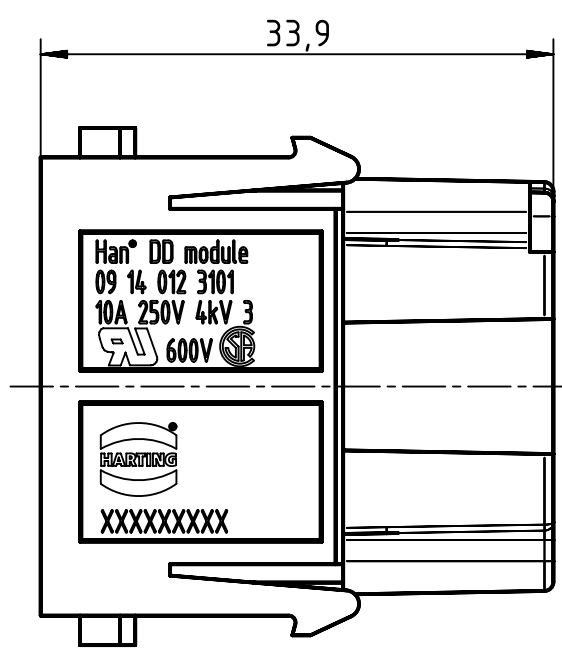
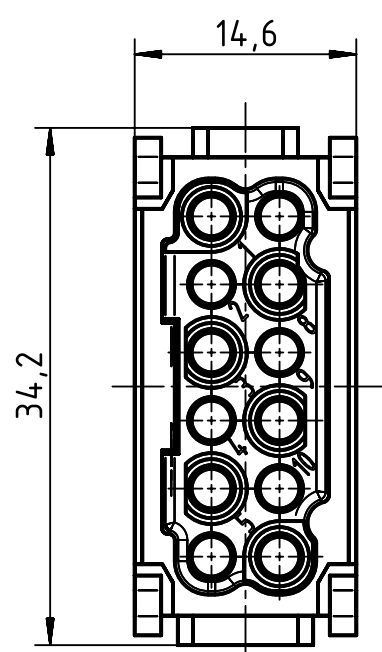



	All Dimensions in mm Original Size DIN A4		Scale 2:1	Free size tol.		Ref.	
						Sub.	
	All rights reserved		Created by RULLKOETTER	Inspected by SCHNIEDER	Standardisation RUETERA	Date 2015-08-10	State Final Release
	Department EL PD - DE		Title Han DD module, crimp female			Doc-Key / ECM-Nr. 100518613/UGD/001/B 500000091604	
HARTING Electric GmbH & Co. KG D-32339 Espelkamp			Type TB	Number 09 14 012 3101		Rev. B	Page 1/1

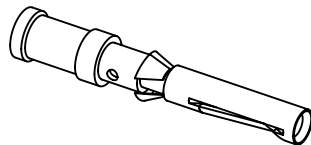

① only for four indent crimping tool adjusting Ø0,1

part no.		ØD	wire gauge		stripping length	
silver plated	gold plated		mm²	AWG		
09 15 000 6204	09 15 000 6224	0,90	0,14-0,37	26-22	8	
09 15 000 6203	09 15 000 6223	1,10	0,5	20		
09 15 000 6205	09 15 000 6225	1,30	0,75	18		
09 15 000 6202	09 15 000 6222	1,45	1	18		
09 15 000 6201	09 15 000 6221	1,75	1,5	16		
09 15 000 6206	09 15 000 6226	2,25	2,5	14	6	
09 15 000 6207	09 15 000 6227	0,90	0,14-0,37	26-22	8	①



	All Dimensions in mm Original Size DIN A4		Scale 2:1	Free size tol.		Ref. Sub. TB 09 15 000 62.. v. 16.06.10	
	All rights reserved Department EL PD - DE		Created by RULLKOETTER	Inspected by SCHNIEDER	Standardisation TIEMANNA	Date 2014-05-20	State Final Release
HARTING Electric GmbH & Co. KG D-32339 Espelkamp		Title Han D crimp contacts female				Doc-Key / ECM-Nr. 100109246/UGD/004/A 500000075030	
		Type TB	Number 09 15 000 62XX			Rev. A	Page 1/1

1 2 3 4 5 6

A

B

C

D

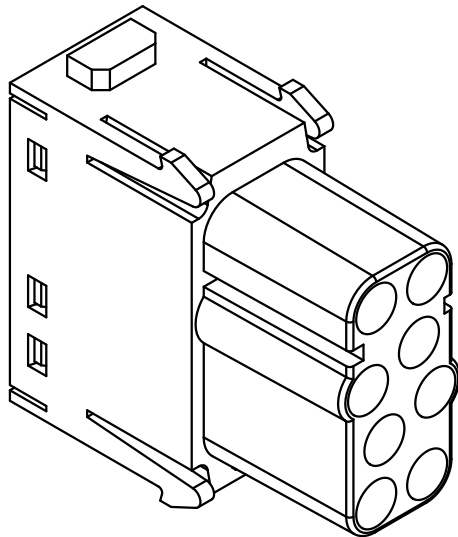
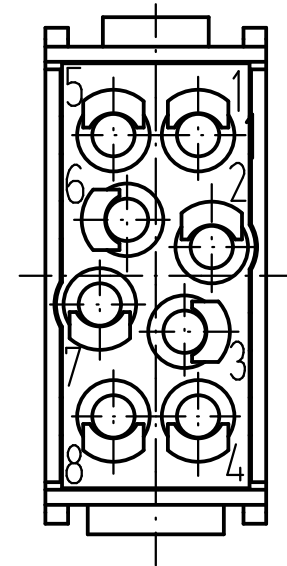
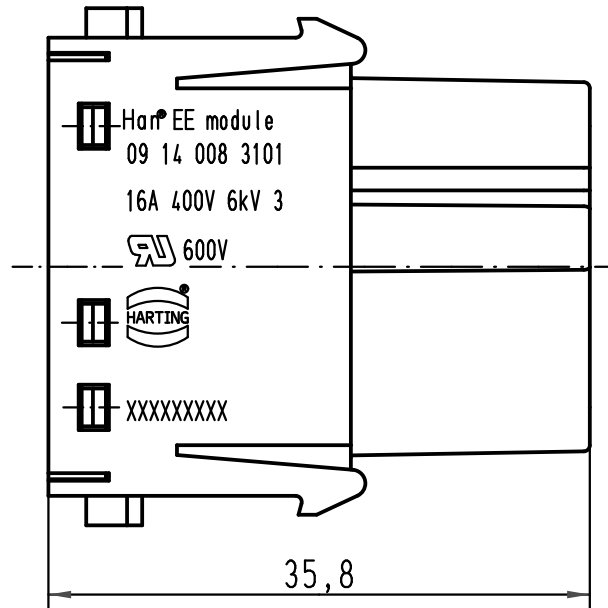
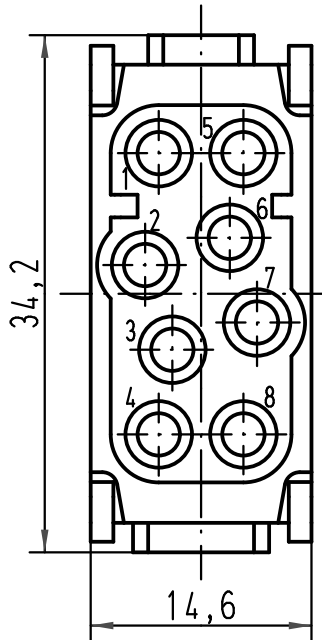

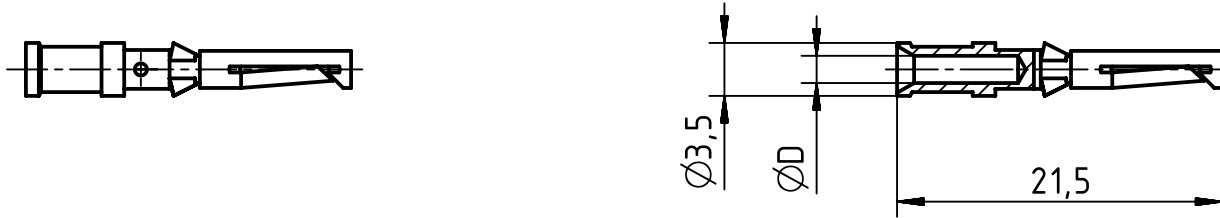

All Dimensions in mm Original Size DIN A 4		Techn. Character.			Nicht tolerierte Maß/Free size tolerances	
			Dat.	Name	Maßstab/Scale 2:1	Han EE module Buchseneinsatz/female insert
		Detail.	10.10.08	Rull		
		Insp.		Be		
		Stand.				
A		HARTING Electric GmbH & Co. KG D-32339 Espelkamp				TB 09 14 008 3101
Mod.	Dat.	Name				
						Blatt/page



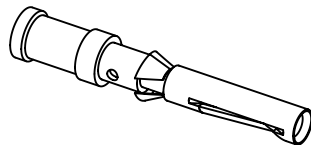

① only for four indent crimping tool adjusting Ø0,1

part no.		ØD	wire gauge		stripping length	
silver plated	gold plated		mm²	AWG		
09 15 000 6204	09 15 000 6224	0,90	0,14-0,37	26-22	8	
09 15 000 6203	09 15 000 6223	1,10	0,5	20		
09 15 000 6205	09 15 000 6225	1,30	0,75	18		
09 15 000 6202	09 15 000 6222	1,45	1	18		
09 15 000 6201	09 15 000 6221	1,75	1,5	16		
09 15 000 6206	09 15 000 6226	2,25	2,5	14	6	
09 15 000 6207	09 15 000 6227	0,90	0,14-0,37	26-22	8	①

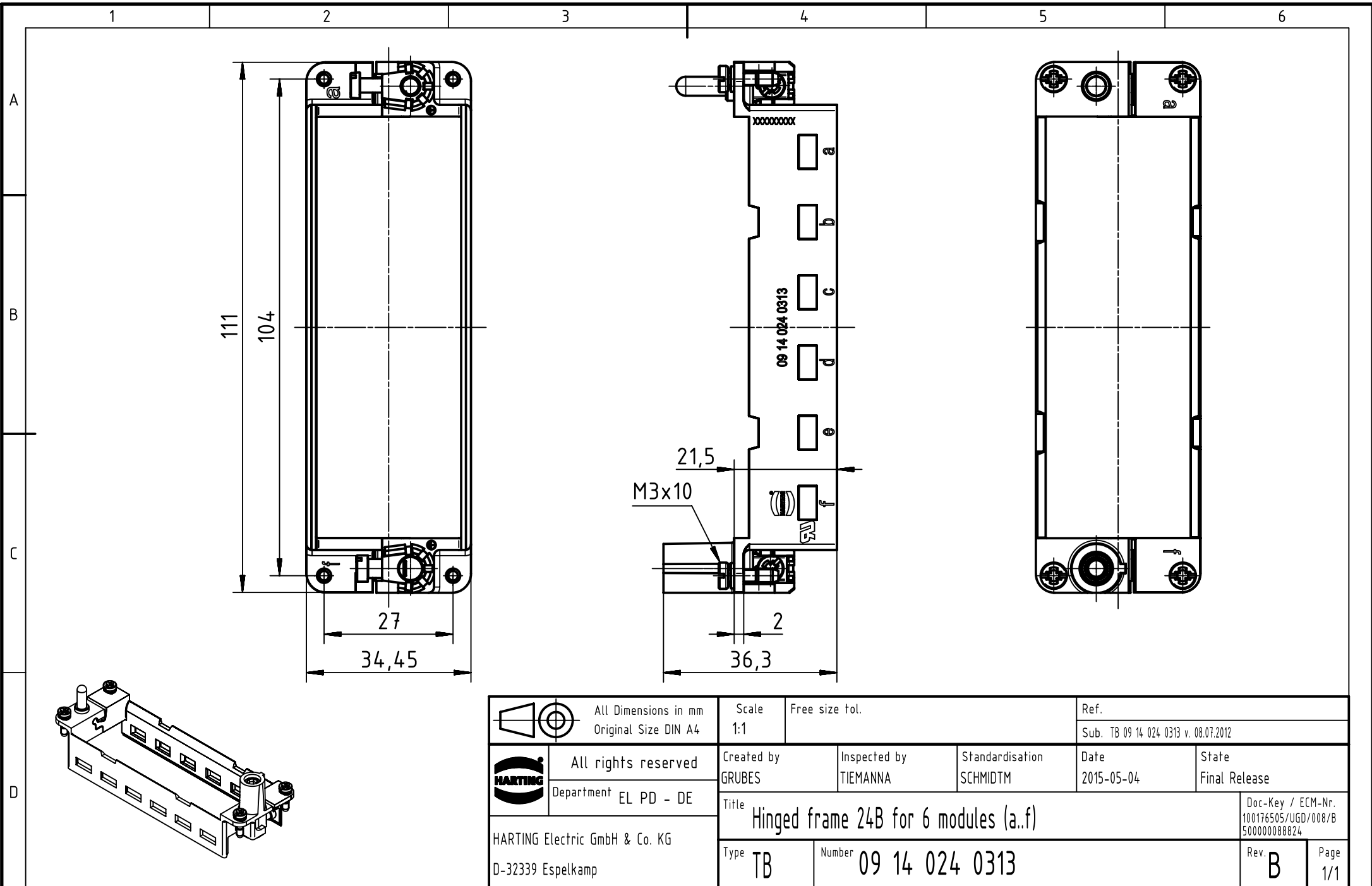

	All rights reserved		Scale 2:1		Free size tol.		Ref.		
	Department EL PD - DE		Created by RULLKOETTER		Inspected by SCHNIEDER		Standardisation TIEMANNA		
HARTING Electric GmbH & Co. KG		D-32339 Espelkamp		Title Han D crimp contacts female				Date 2014-05-20	
				Type TB				Number 09 15 000 62XX	
								State Final Release	
								Doc-Key / ECM-Nr. 100109246/UGD/004/A 500000075030	
								Rev. A	
								Page 1/1	



	All rights reserved Department EL PD - DE	All Dimensions in mm Original Size DIN A4		Scale 1:1	Free size tol.	Ref. Sub. TB 09 14 024 0313 v. 08.07.2012	
		Created by GRUBES	Inspected by TIEMANNA	Standardisation SCHMIDTM	Date 2015-05-04	State Final Release	
HARTING Electric GmbH & Co. KG D-32339 Espelkamp		Title Hinged frame 24B for 6 modules (a.f)				Doc-Key / ECM-Nr. 100176505/UGD/008/B 500000088824	
		Type TB	Number 09 14 024 0313		Rev. B	Page 1/1	

A

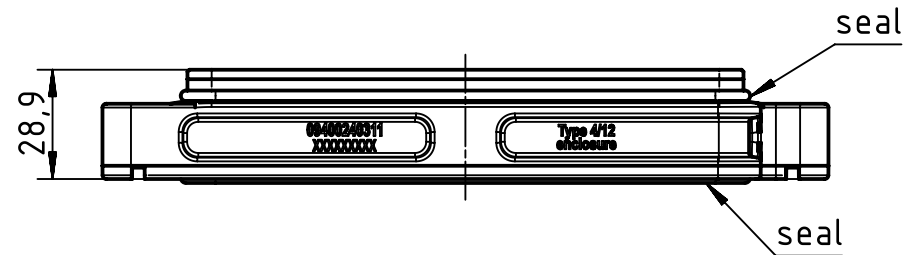

B

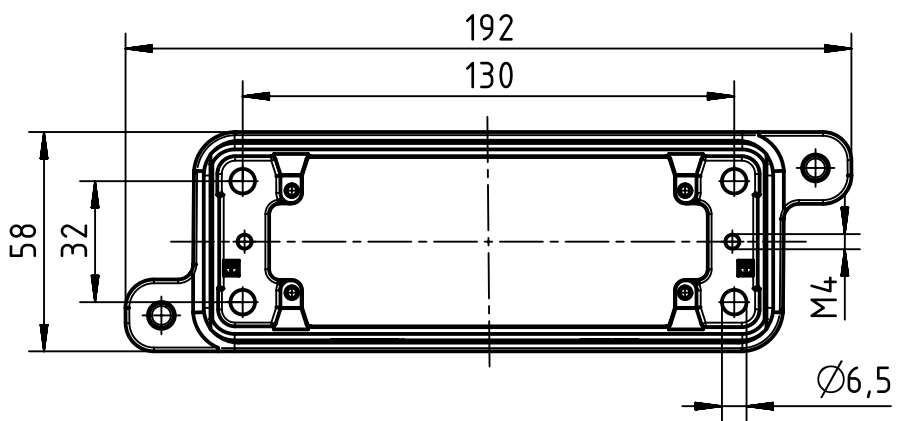

panel cut out for EMC features, conductive surface

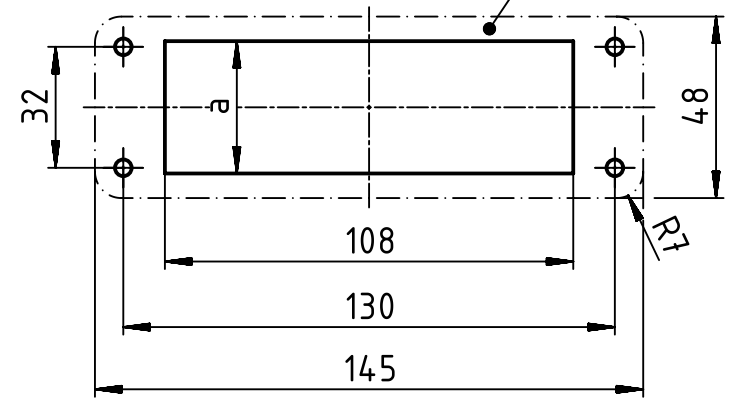

C

application	a
standard insert	35
HC-Modular 650	44,5

D

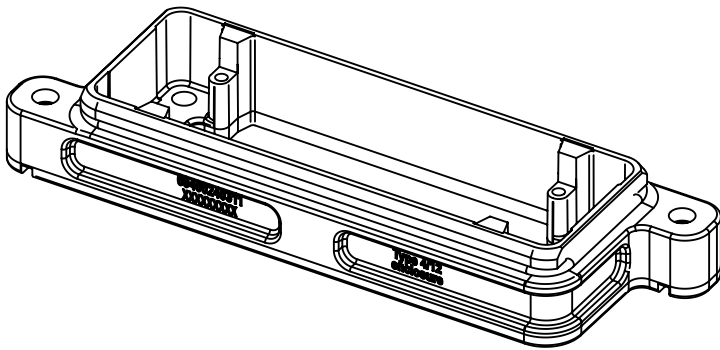

	All Dimensions in mm Original Size DIN A4		Scale 1:2	Free size tol.		Ref.	
	All rights reserved Department EL PD - DE		Created by FINKEV	Inspected by GERB	Standardisation TIEMANNA	Date 2015-11-13	State Final Release
HARTING Electric GmbH & Co. KG D-32339 Espelkamp		Title Han 24HPR Base Panel Screw locking				Doc-Key / ECM-Nr. 100217699/UGD/004/C 500000093625	
		Type TB	Number 09 40 024 0311			Rev. C	Page 1/1

TRENES ARGENTINOS OPERACIONES

DOCUMENTACIÓN TÉCNICA PARA COMPRA

NUM43360810340N

Descripción: Conector macho aéreo, 8x2 polos p/ethernet-profibus + 12x2 polos, sección 0,14-2,5mm², salida recta M40. Conector para cable de entre coches XSP93. Fichas y terminales. Cables y accesorios. Sistema colector y distribución. CCEE CSR.

Plano N°: No Corresponde

Planos concatenados N°: No Corresponde

Referencia de fábrica: (Descrito en hoja 2)

Especificación Técnica: ET MRR/G-007, última emisión.

Norma de aplicación: No Corresponde

Inserto contacto Macho para conectores de entre coche XSP93.

Función:

	ELABORÓ	REVISÓ	APROBÓ
NOMBRE	G. Barborini	Ing. H. Baigorria	Ing. C. Valdes Lazo
FIRMA	-	-	-



CONFORMADO POR:

- RF: 09 14 002 3001 - Cantidad 2 (Harting)
- RF: 09 15 004 3013 - Cantidad 4 (Harting)
- RF: 09 15 000 6123 - Cantidad 16 (Harting)
- RF: 09 14 012 3001 - Cantidad 2 (Harting)
- RF: 09 15 000 6105 - Cantidad 18 (Harting)
- RF: 09 14 024 0303 - Cantidad 1 (Harting)
- RF: 19 40 024 0413 - Cantidad 1 (Harting)

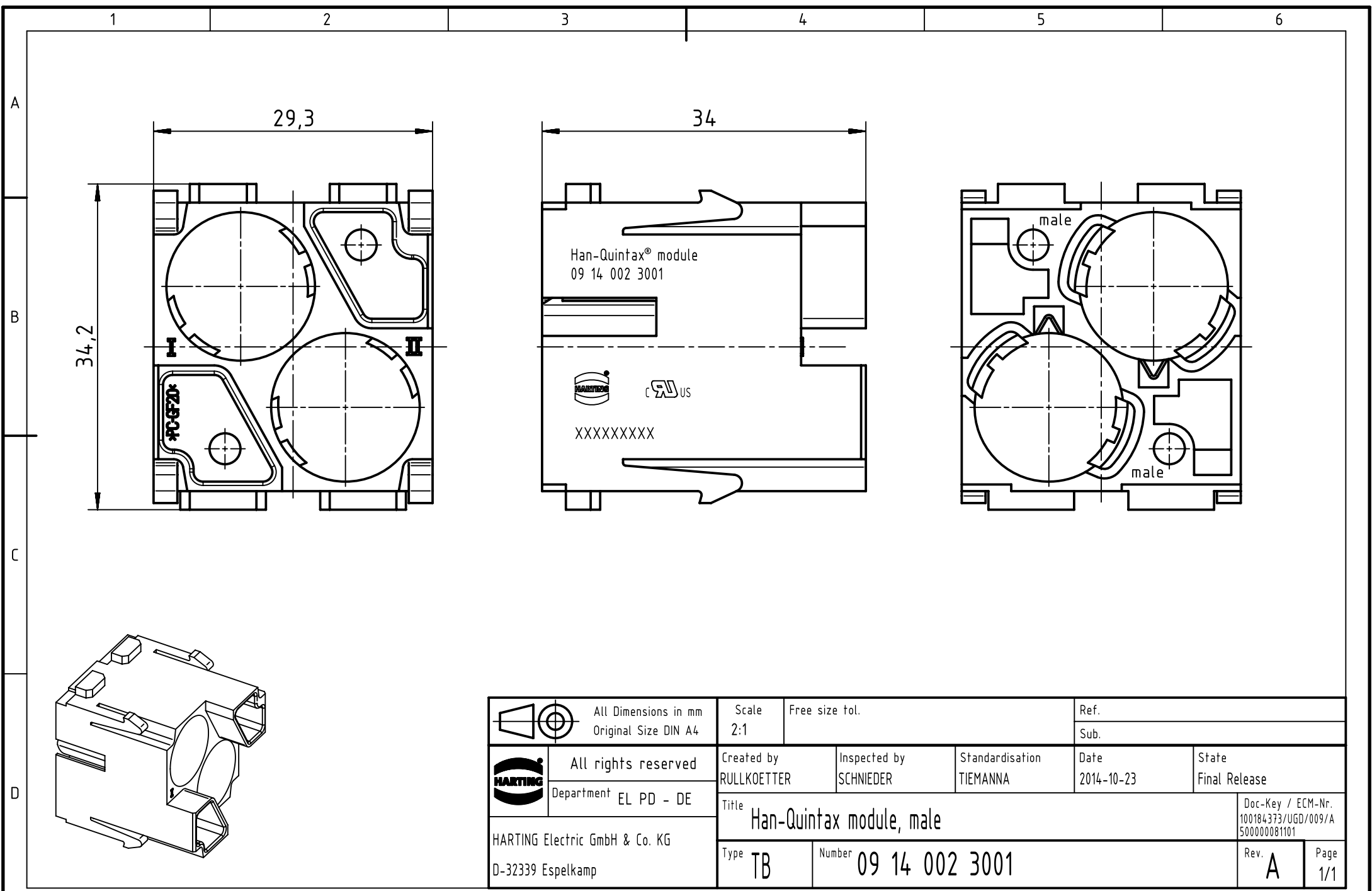

	All Dimensions in mm Original Size DIN A4		Scale 2:1	Free size tol.		Ref.	
	All rights reserved Department EL PD - DE		Created by RULLKOETTER	Inspected by SCHNIEDER	Standardisation TIEMANNA	Date 2014-10-23	State Final Release
HARTING Electric GmbH & Co. KG D-32339 Espelkamp			Title Han-Quintax module, male			Doc-Key / ECM-Nr. 100184373/UGD/009/A 500000081101	
			Type TB	Number 09 14 002 3001		Rev. A	Page 1/1

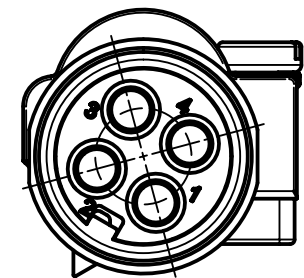
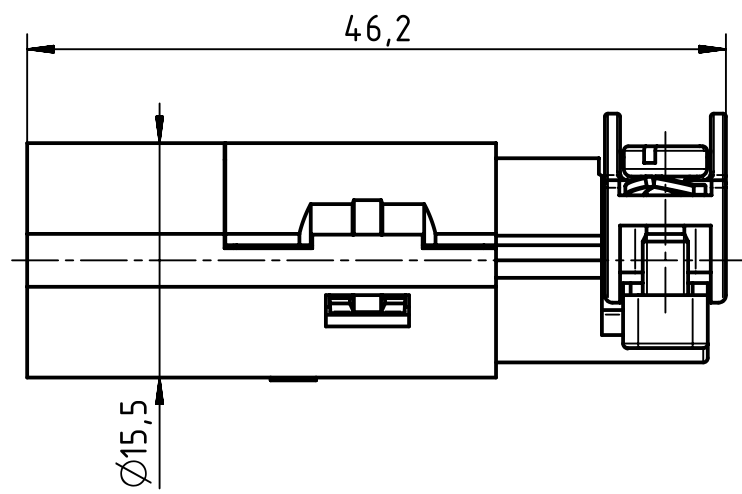
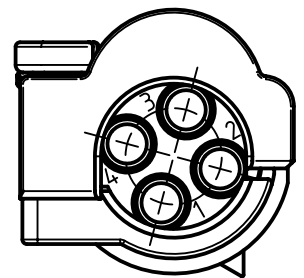
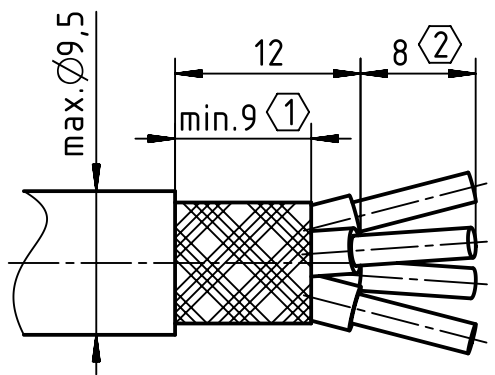

Recommended Ethernet connection

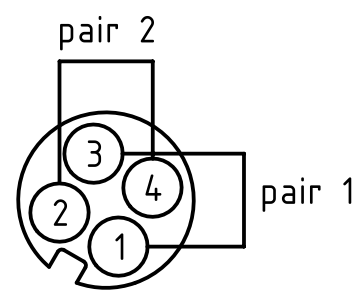

Pin	10BASE-T 100BASE-TX	colour
1	Tx+	white/orange
2	Rx+	white/green
3	Tx-	orange
4	Rx-	green

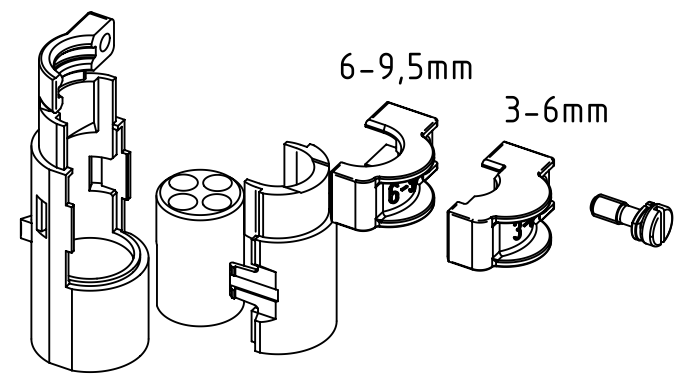

kind of delivery: piece parts

① till screening braid over cable jacket
recommendation: fix end of screening braid
(more than 9mm) with shrinking tube

② stripping length of a 2,5mm²
wire gauge is 6mm

	All Dimensions in mm Original Size DIN A4		Scale 2:1	Free size tol.		Ref.	
	All rights reserved Department EL PD - DE		Created by RULLKOETTER	Inspected by GERB	Standardisation TIEMANNA	Date 2015-01-14	
HARTING Electric GmbH & Co. KG D-32339 Espelkamp		Title Han-Quintax contact male, 3-9.5mm				State Final Release	Doc-Key / ECM-Nr. 100172437/UGD/003/B 500000083549
			Type TB	Number 09 15 004 3013		Rev. B	Page 1/1

1 2 3 4 5 6

A

B

C

D

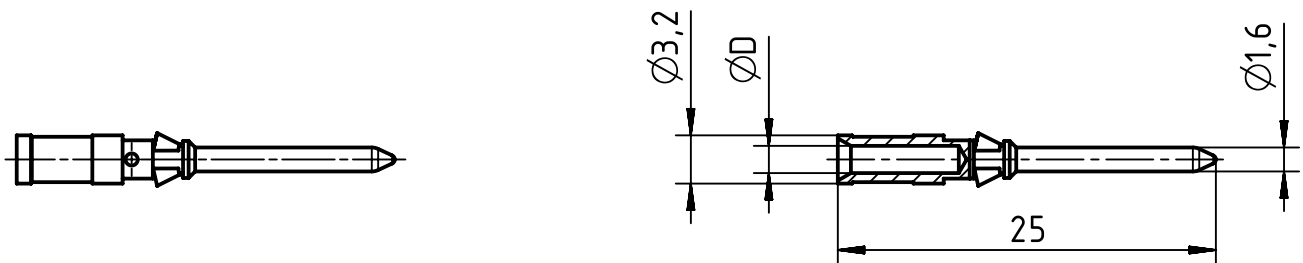

① only for four indent crimping tool adjusting Ø0,1

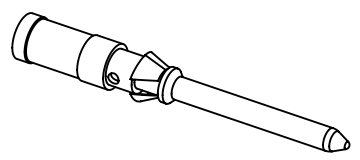

part no.		ØD	wire gauge		stripping length	
silver plated	gold plated		mm²	AWG		
09 15 000 6104	09 15 000 6124	0,90	0,14-0,37	26-22	8	
09 15 000 6103	09 15 000 6123	1,10	0,5	20		
09 15 000 6105	09 15 000 6125	1,30	0,75	18		
09 15 000 6102	09 15 000 6122	1,45	1	18		
09 15 000 6101	09 15 000 6121	1,75	1,5	16		
09 15 000 6106	09 15 000 6126	2,25	2,5	14	6	
09 15 000 6107	09 15 000 6127	0,90	0,14-0,37	26-22	8	①

	All rights reserved		Scale 2:1	Free size tol.		Ref.		
	Department EL PD - DE		Created by RULLKOETTER	Inspected by SCHNIEDER	Standardisation TIEMANNA	Date 2014-05-20	State Final Release	
HARTING Electric GmbH & Co. KG		Title Han D crimp contacts male					Doc-Key / ECM-Nr. 100086611/UGD/006/A 500000075030	
D-32339 Espelkamp		Type TB	Number 09 15 000 61XX			Rev. A	Page 1/1	

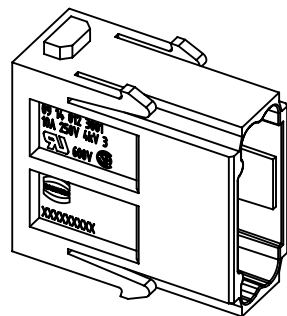
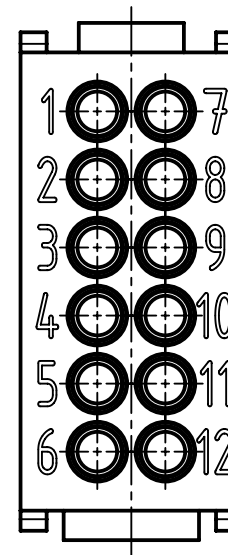
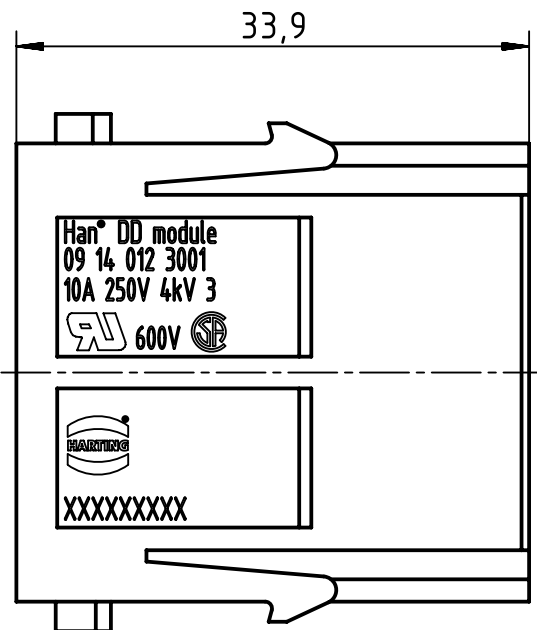
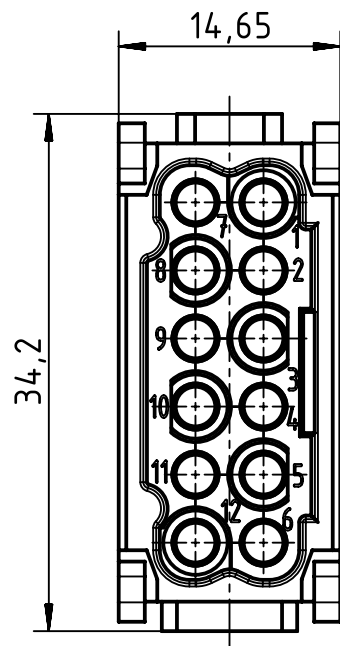

	All Dimensions in mm Original Size DIN A4		Scale 2:1	Free size tol.		Ref. Sub. TB 09 14 012 3001 v. 03.11.94		
		All rights reserved Department EL PD - DE	Created by RULLKOETTER	Inspected by SCHNIEDER	Standardisation RUETERA	Date 2015-08-10	State Final Release	
Title Han DD module, crimp male						Doc-Key / ECM-Nr. 100518533/UGD/001/C 500000091604		
HARTING Electric GmbH & Co. KG D-32339 Espelkamp			Type TB	Number 09 14 012 3001			Rev. C	Page 1/1

1 2 3 4 5 6

A

B

C

D

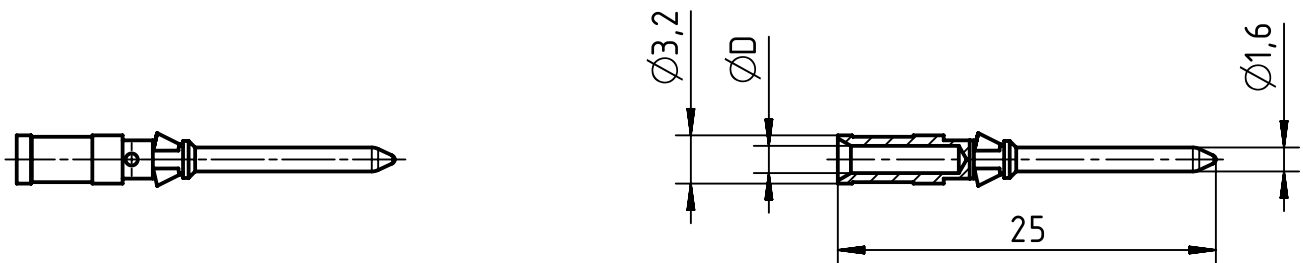

① only for four indent crimping tool adjusting $\varnothing 0,1$

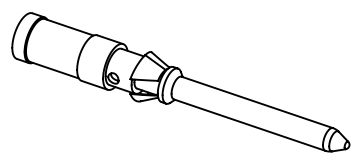

part no.		$\varnothing D$	wire gauge		stripping length	
silver plated	gold plated		mm ²	AWG		
09 15 000 6104	09 15 000 6124	0,90	0,14-0,37	26-22	8	
09 15 000 6103	09 15 000 6123	1,10	0,5	20		
09 15 000 6105	09 15 000 6125	1,30	0,75	18		
09 15 000 6102	09 15 000 6122	1,45	1	18		
09 15 000 6101	09 15 000 6121	1,75	1,5	16		
09 15 000 6106	09 15 000 6126	2,25	2,5	14	6	
09 15 000 6107	09 15 000 6127	0,90	0,14-0,37	26-22	8	①

	All rights reserved		Scale 2:1	Free size tol.	Ref.	
	Department EL PD - DE		Created by RULLKOETTER	Inspected by SCHNIEDER	Standardisation TIEMANNA	Date 2014-05-20
HARTING Electric GmbH & Co. KG		Title Han D crimp contacts male			State Final Release	Doc-Key / ECM-Nr. 100086611/UGD/006/A 500000075030
D-32339 Espelkamp		Type TB	Number 09 15 000 61XX		Rev. A	Page 1/1

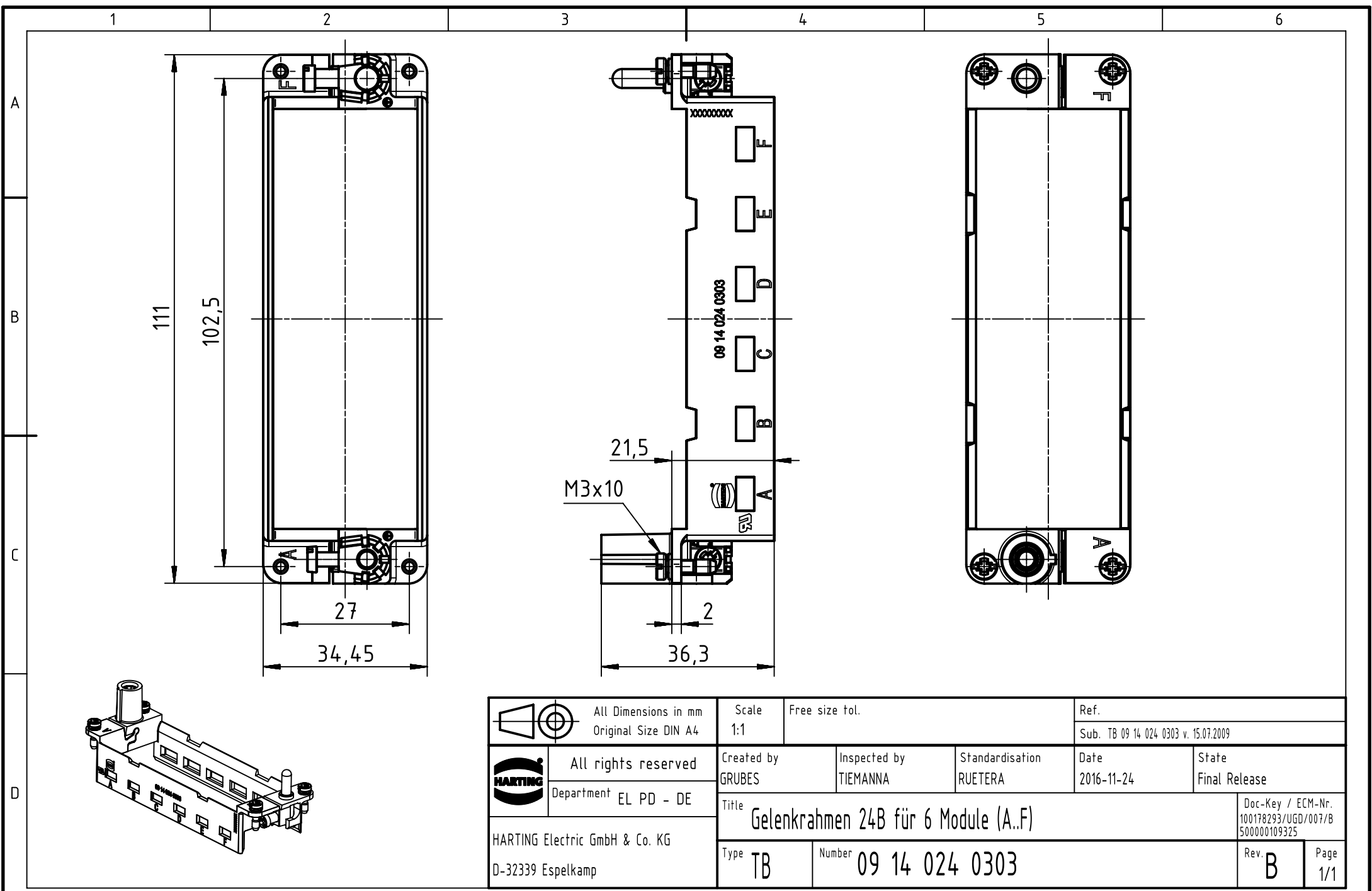

	All Dimensions in mm Original Size DIN A4		Scale 1:1	Free size tol.		Ref. Sub. TB 09 14 024 0303 v. 15.07.2009		
		All rights reserved Department EL PD - DE		Created by GRUBES	Inspected by TIEMANNA	Standardisation RUETERA	Date 2016-11-24	State Final Release
HARTING Electric GmbH & Co. KG D-32339 Espelkamp						Title Gelenkrahmen 24B für 6 Module (A..F)		Doc-Key / ECM-Nr. 100178293/UGD/007/B 500000109325
				Type TB	Number 09 14 024 0303		Rev. B	Page 1/1

1 2 3 4 5 6

X (2:1)

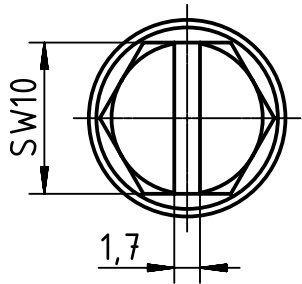

M 40x1,5

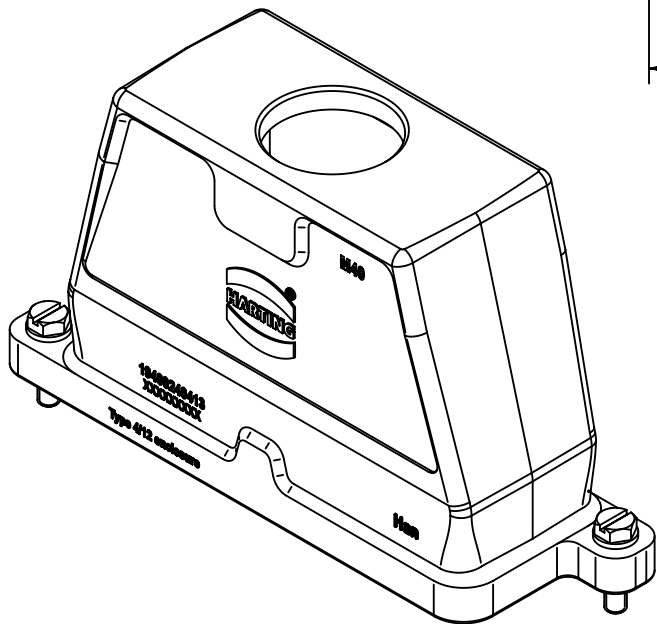
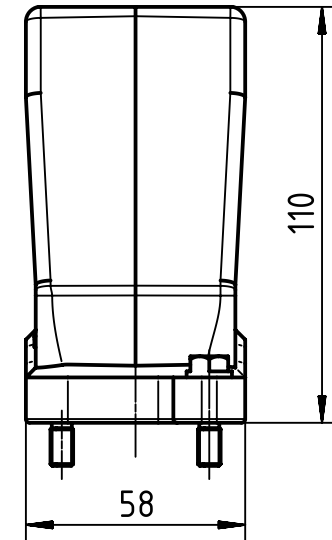
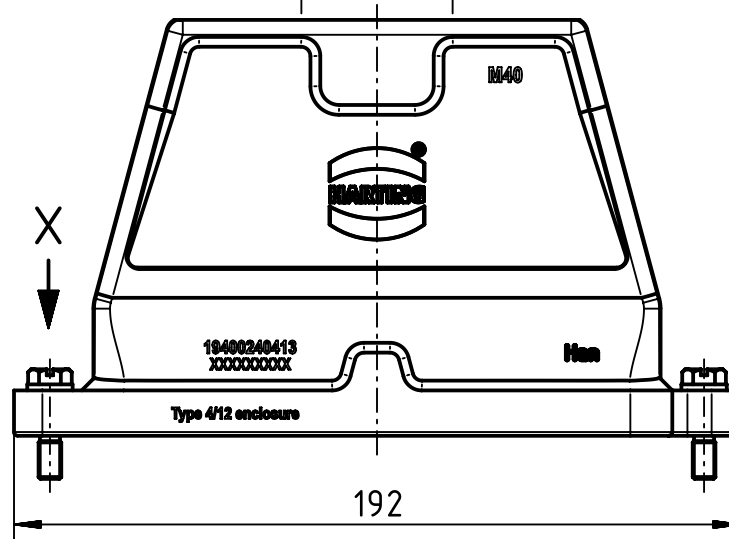

	All Dimensions in mm Original Size DIN A4		Scale 1:2	Free size tol.		Ref. Sub. TB 19 40 024 0413 v. 10.01.11			
		All rights reserved Department EL PD - DE		Created by FINKEV	Inspected by GERB	Standardisation TIEMANNA	Date 2015-11-13	State Final Release	
HARTING Electric GmbH & Co. KG D-32339 Espelkamp				Title Han 24 HPR Hood Top Entry M40 Screw Lock			Doc-Key / ECM-Nr. 10020194.9/UGD/004/B 500000094.164		
				Type TB	Number 19 40 024 0413			Rev. B	Page 1/1

TRENES ARGENTINOS OPERACIONES

DOCUMENTACIÓN TÉCNICA PARA COMPRA

NUM43360810350N

Descripción: Conector p/chasis, hembra, 8x2 polos p/ethernet-profibus + 12x2 polos, sección 0,14-2,5mm². Conector para cable de entre coches XSP94. Fichas y terminales. Cables y accesorios. Sistema colector y distribución. CCEE CSR.

Plano N°: *No Corresponde*

Planos concatenados N°: *No Corresponde*

Referencia de fábrica: *(Descripto en hoja 2)*

Especificación Técnica: *ET MRR/G-007, última emisión.*

Norma de aplicación: *No Corresponde*

Función: *Inserto contacto Hembra para conectores de entre coche XSP94.*

	ELABORÓ	REVISÓ	APROBÓ
NOMBRE	G. Barborini	Ing. H. Baigorria	Ing. C. Valdes Lazo
FIRMA	-	-	-



CONFORMADO POR:

- RF: 09 14 002 3101 - Cantidad 2 (Harting)
- RF: 09 15 004 3113 - Cantidad 4 (Harting)
- RF: 09 15 000 6223 - Cantidad 16 (Harting)
- RF: 09 14 012 3101 - Cantidad 2 (Harting)
- RF: 09 15 000 6205 - Cantidad 18 (Harting)
- RF: 09 14 024 0313 - Cantidad 1 (Harting)
- RF: 09 40 024 0311 - Cantidad 1 (Harting)

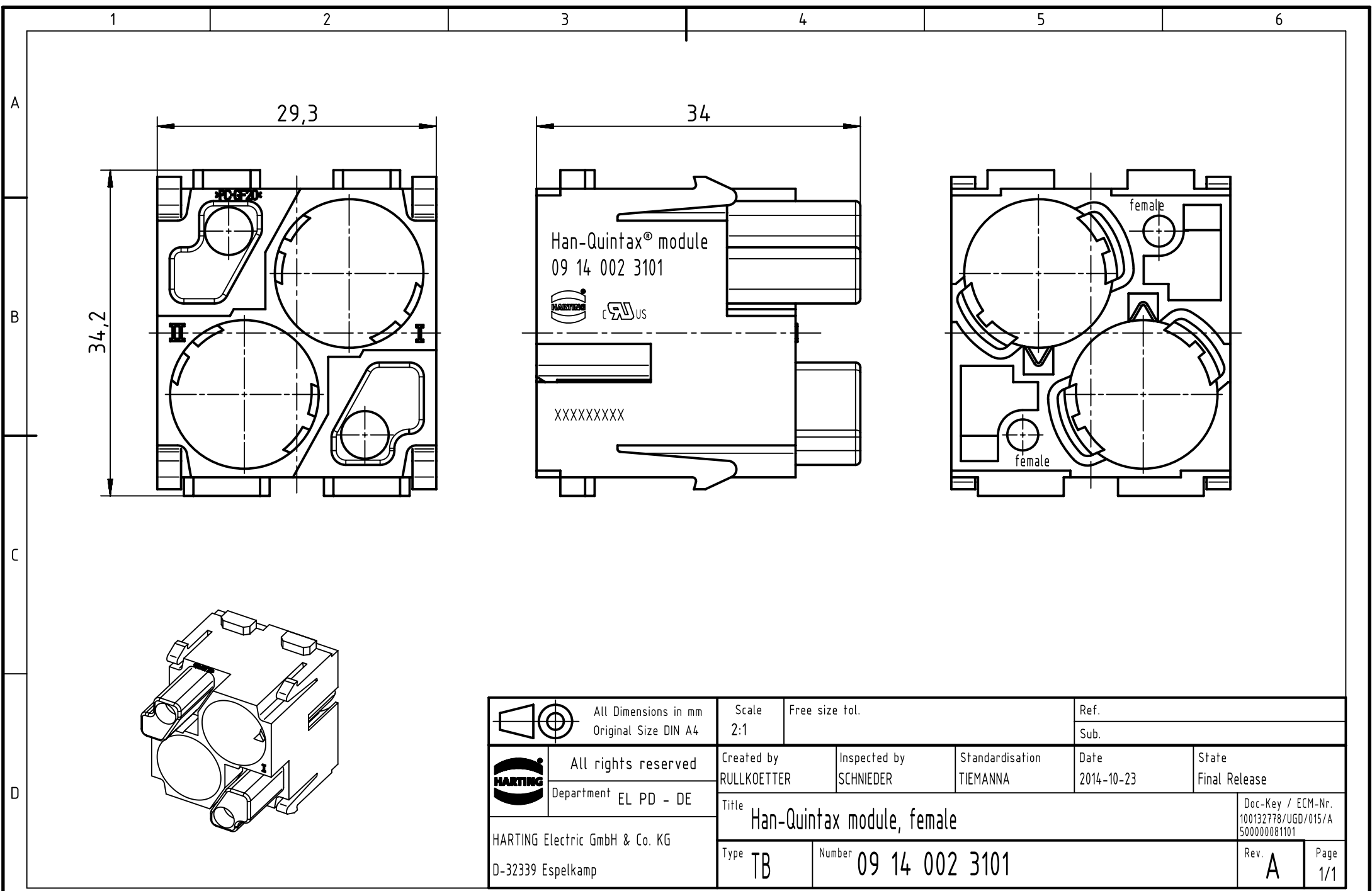

	All Dimensions in mm Original Size DIN A4		Scale 2:1	Free size tol.		Ref.	
						Sub.	
	All rights reserved		Created by RULLKOETTER	Inspected by SCHNIEDER	Standardisation TIEMANNA	Date 2014-10-23	State Final Release
	Department EL PD - DE		Title Han-Quintax module, female			Doc-Key / ECM-Nr. 100132778/UGD/015/A 500000081101	
HARTING Electric GmbH & Co. KG D-32339 Espelkamp			Type TB	Number 09 14 002 3101		Rev. A	Page 1/1

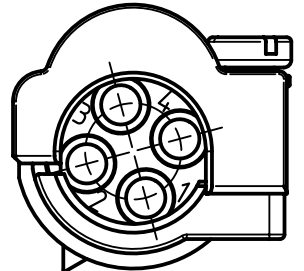
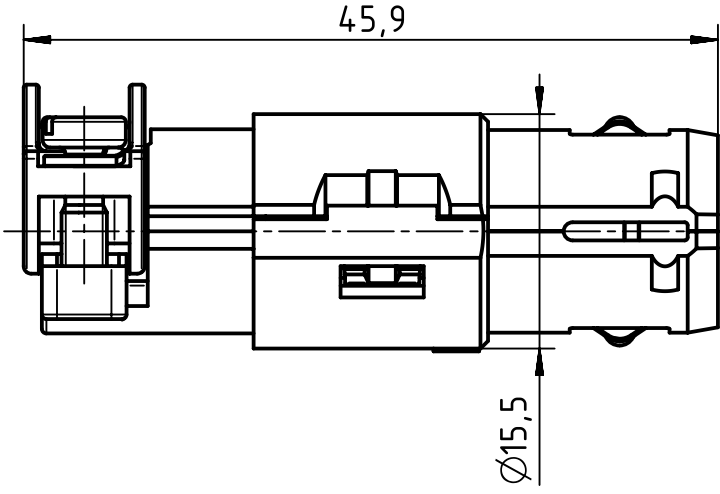
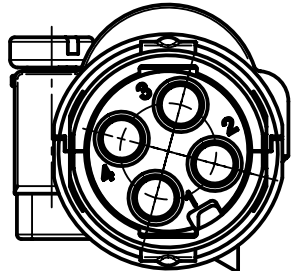
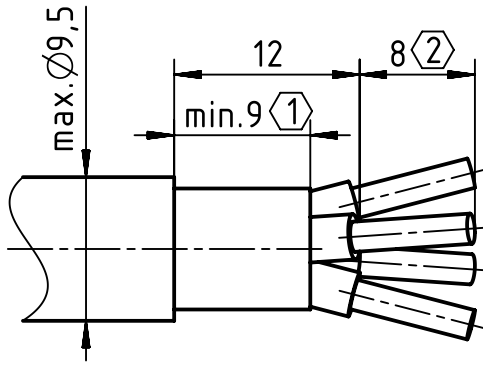

Recommended Ethernet connection

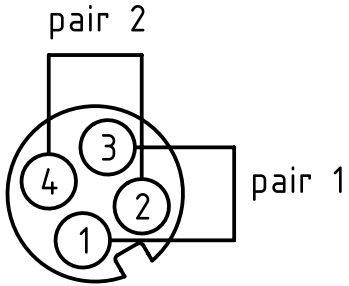

Pin	10BASE-T 100BASE-TX	colour
1	Tx+	white/orange
2	Rx+	white/green
3	Tx-	orange
4	Rx-	green

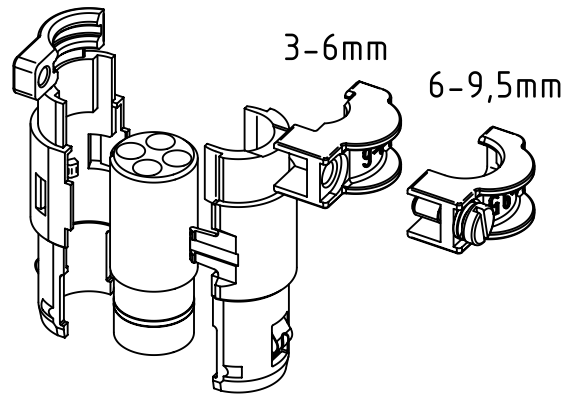

kind of delivery: piece parts

① till screening braid over cable jacket recommendation:

fix end of screening braid (more than 9mm) with shrinking tube

② stripping length of a 2,5mm² wire gauge is 6mm

	All rights reserved Department EL PD - DE	All Dimensions in mm Original Size DIN A4		Scale 2:1	Free size tol.	Ref.
		HARTING Electric GmbH & Co. KG D-32339 Espelkamp	Created by RULLKOETTER	Inspected by GERB	Standardisation TIEMANNA	Date 2015-01-14
Title Han-Quintax contact female, 3-9.5mm						Doc-Key / ECM-Nr. 100172441/UGD/005/B 500000083549
Type TB				Number 09 15 004 3113		Rev. B
						Page 1/1

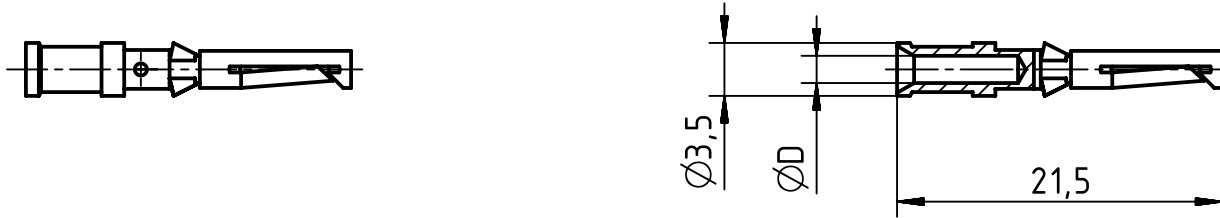

① only for four indent crimping tool adjusting Ø0,1

part no.		ØD	wire gauge		stripping length	
silver plated	gold plated		mm²	AWG		
09 15 000 6204	09 15 000 6224	0,90	0,14-0,37	26-22	8	
09 15 000 6203	09 15 000 6223	1,10	0,5	20		
09 15 000 6205	09 15 000 6225	1,30	0,75	18		
09 15 000 6202	09 15 000 6222	1,45	1	18		
09 15 000 6201	09 15 000 6221	1,75	1,5	16		
09 15 000 6206	09 15 000 6226	2,25	2,5	14	6	
09 15 000 6207	09 15 000 6227	0,90	0,14-0,37	26-22	8	①

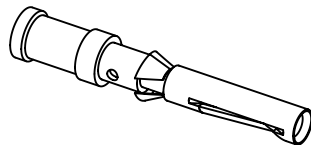

	All Dimensions in mm Original Size DIN A4		Scale 2:1	Free size tol.		Ref. Sub. TB 09 15 000 62.. v. 16.06.10	
	All rights reserved Department EL PD - DE		Created by RULLKOETTER	Inspected by SCHNIEDER	Standardisation TIEMANNA	Date 2014-05-20	State Final Release
HARTING Electric GmbH & Co. KG D-32339 Espelkamp		Title Han D crimp contacts female				Doc-Key / ECM-Nr. 100109246/UGD/004/A 500000075030	
		Type TB	Number 09 15 000 62XX			Rev. A	Page 1/1

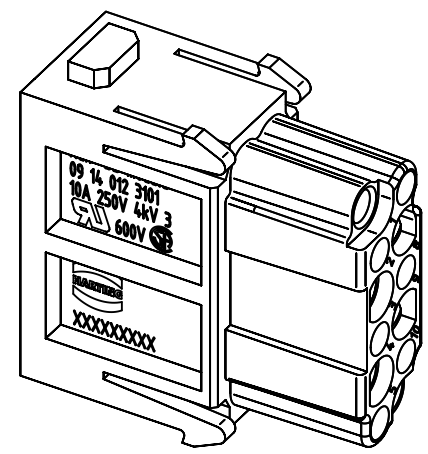
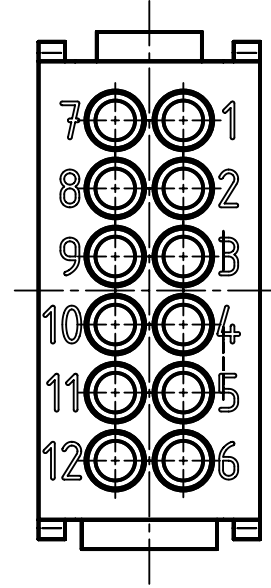
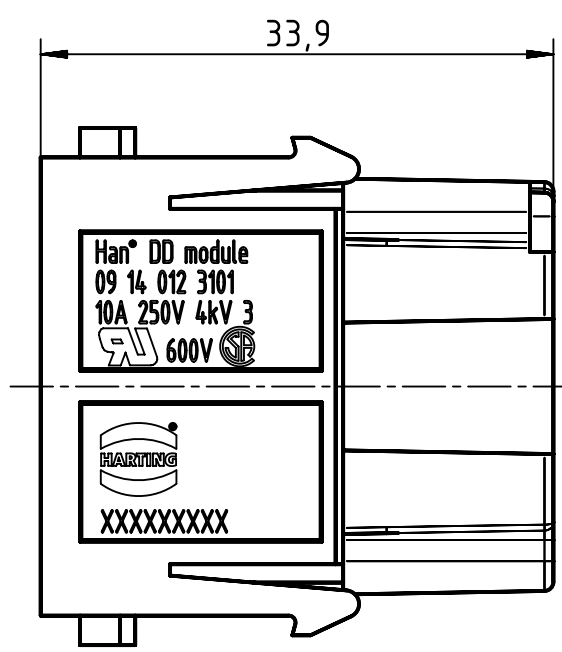
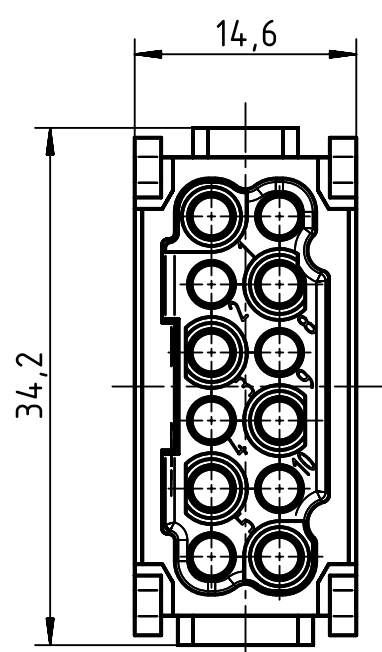

	All Dimensions in mm Original Size DIN A4		Scale 2:1	Free size tol.		Ref.	
						Sub.	
	All rights reserved Department EL PD - DE		Created by RULLKOETTER	Inspected by SCHNIEDER	Standardisation RUETERA	Date 2015-08-10	State Final Release
	HARTING Electric GmbH & Co. KG D-32339 Espelkamp		Title Han DD module, crimp female			Doc-Key / ECM-Nr. 100518613/UGD/001/B 500000091604	
			Type TB	Number 09 14 012 3101		Rev. B	Page 1/1