

NUM 00810108310  
R/F 9089551

Tolerancias salvo especificación  
JS 14 = js 14 IRAM 5002

Simbolos de labrado  
IRAM 4517

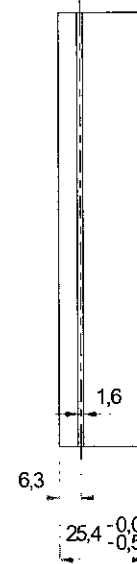
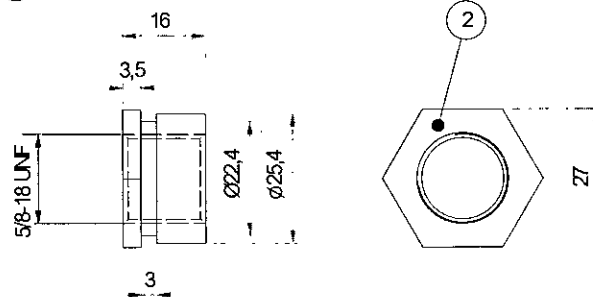
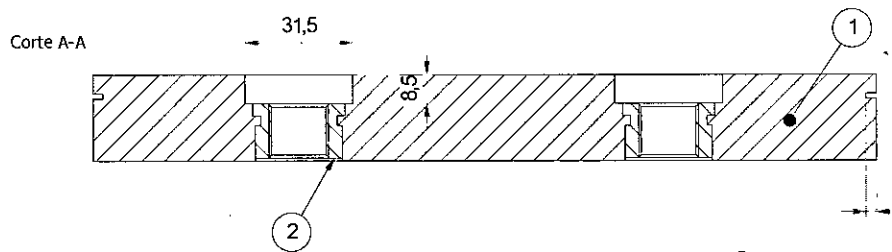
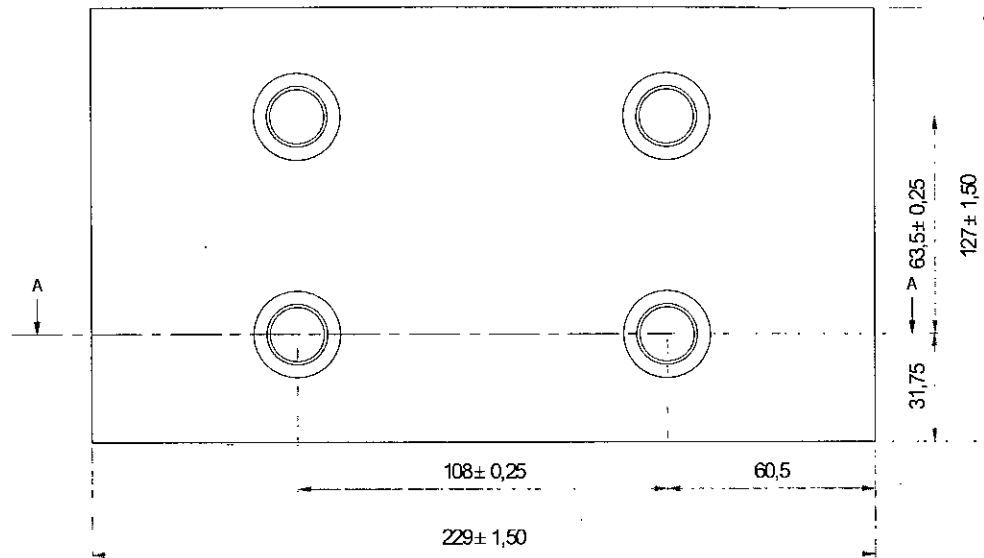

Zona de grabado

Para instalar esta pieza, arrime completamente a la viga Bolster, aplicando un torque de 130 Lb-ft  
NOTA 1: El proveedor entregara la pieza acompañada del certificado de material de la placa.  
NOTA 2: Deberá figurar en forma permanente, en la zona de grabado, el número de Orden de Compra.

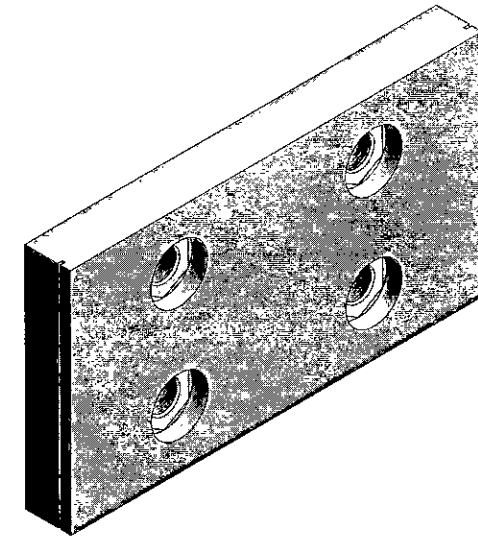

*Juan Manuel Kysilka*  
**Juan Manuel Kysilka**  
Coord. Gral de Ingeniería  
Línea Belgrano Sur  
Trenes Argentinos  
Operadora Ferroviaria

ITEM	DENOMINACIÓN	MATERIAL	CTDAD
1	Placa	NYLATRON® GS/GSM	1
2	Tuerca	Aceero SAE 1010.	4

Fecha:		 LINEA GRAL ROCA ARGENTREN S.A.	N° de plano: 00810108310										
Dibujo:	Ing. C. Valdes												
Revisa:													
Aprobó:	Ing. D. Iglesias		Utilización: Eggle Loos ET 22 O/V										
Emisión:	Escala S/Esc	Título:											
<table border="1"> <tr> <td>A</td><td>B</td><td>C</td><td>D</td><td>⊕</td> </tr> <tr> <td>E</td><td>F</td><td>G</td><td>H</td><td>rocha 16/6</td> </tr> </table>		A	B	C	D	⊕	E	F	G	H	rocha 16/6	<b>Placa de desgaste Lateral</b> <b>Mesa flotante</b>	
A	B	C	D	⊕									
E	F	G	H	rocha 16/6									

Em. C: se modificó el material de la placa. 03-07-2014  
Em. B: se modificó el valor de la rosca de la tuerca. 26-06-2013