

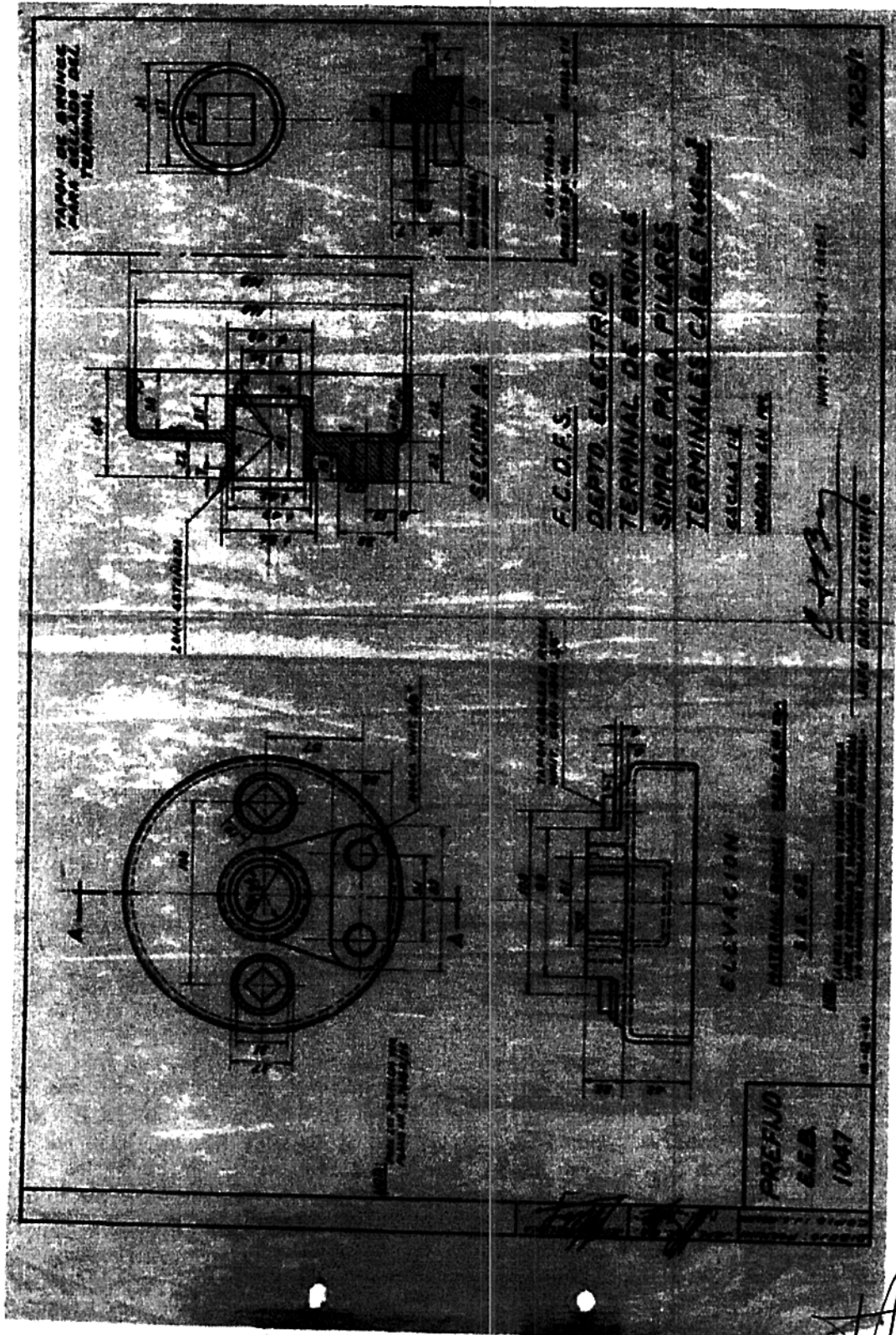



ADIF

Administración de Infraestructura  
Ferrocarril del Uruguay



DCD LIC ADYE 11-14 54 - Planos y Esquemas

  
 Ing. HORACIO GONI VILLAVICENCIO  
 SUBGERENTE DE INFRAESTRUCTURA  
 LINEA MITRE  
 OPERADORA FERROVIARIA

CORTE A-A

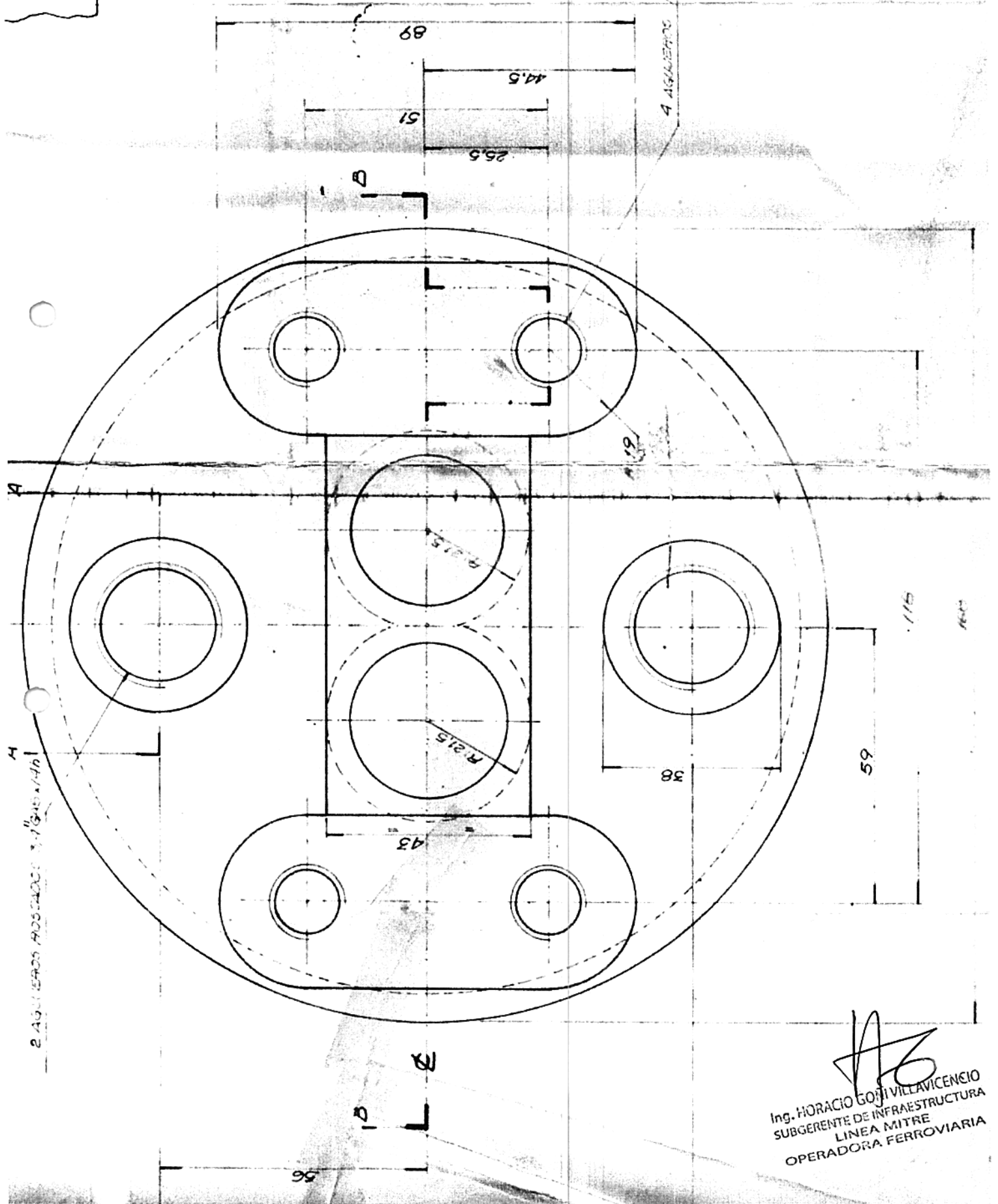

Ing. HORACIO GOTTI VILLAVICENCIO  
SUBGERENTE DE INFRAESTRUCTURA  
LINEA MITRE  
OPERADORA FERROVIARIA

(1)

(4)

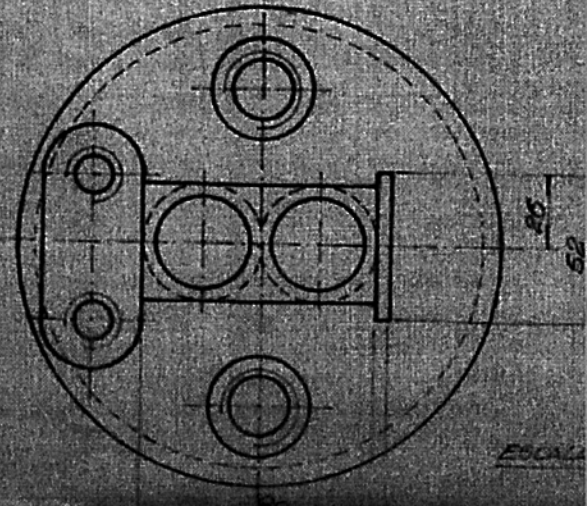
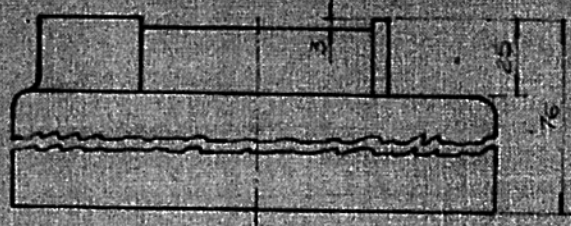

ESCALA 1:20

PARA OTRAS DIMENSIONES VER ITEM 1

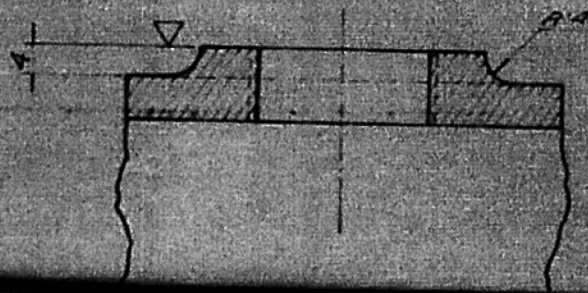

Ing. HORACIO GONZALEZ VILLAVICENCIO  
SUBGERENTE DE INFRAESTRUCTURA  
LINEA MITRE  
OPERADORA FERROVIARIA



1

ESCALA 1:1

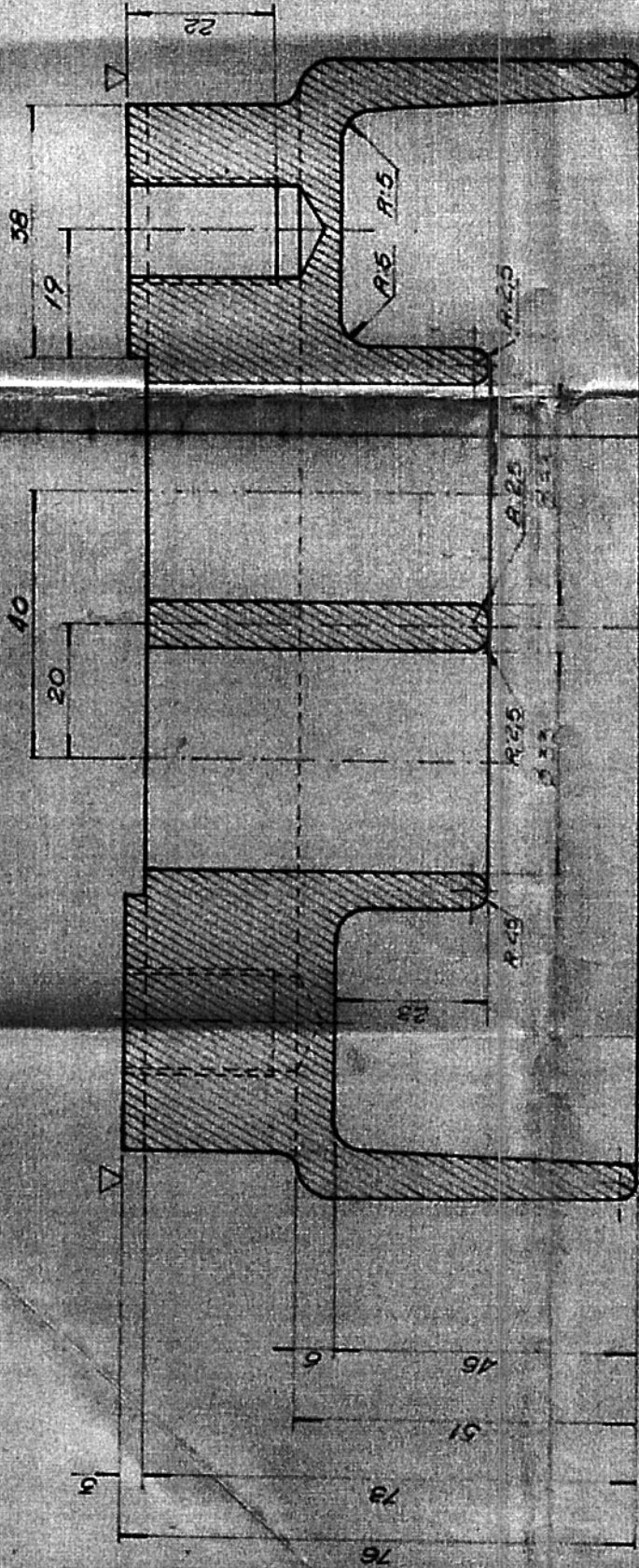

CORTE B-B

Ing. HORACIO GONZALEZ  
SUBGERENTE DE INFRAESTRUCTURA  
LINEA MITRE  
OPERADORA FERROVIARIA

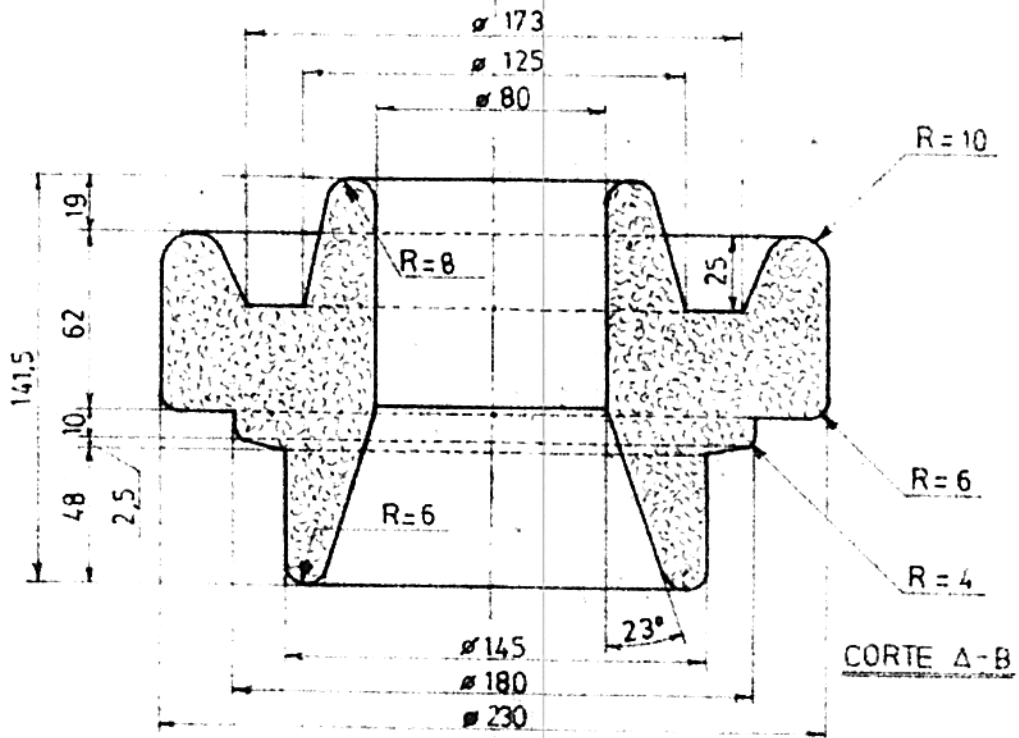
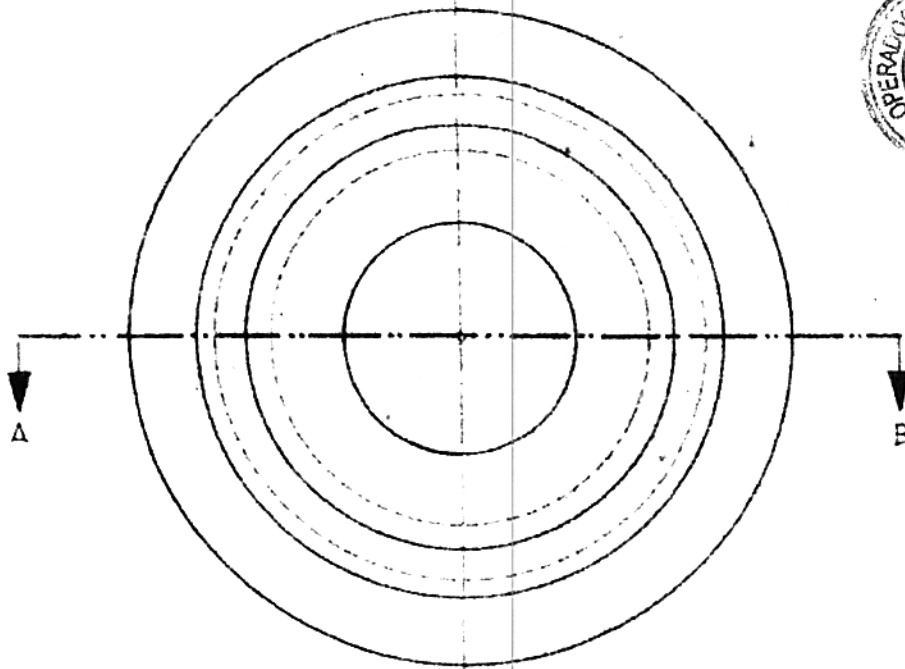

**MATERIAL:** PORCELANA VITRIFICADA

**TOLERANCIA:**  $\pm 2\%$

<b>TITULO</b> PILAR TERMINAL PARA CABLE INTER- CONECTOR - (2 x 398,7 mm <sup>2</sup> ) Acc.: AISLADOR			FERROVIARIOS ARGENTINOS <b>AREA:</b> <b>DEPARTAMENTO ELECTRICO</b>		
<b>ESCALA</b>	<b>TROCHA</b>	<b>LINEA</b>	<b>UTILIZACION:</b>	<b>EMISIONES</b>	
1:2,5	1.676	MITRE	DIV S.E y REDES	1	
<b>FECHA Y FIRMA DPROB.</b>		<b>Nº DE PLANO:</b>		INGENIERO SUBGERENTE DE INFRAESTRUCTURA LINEA MITRE OPERADORA FERROVIARIA	

DIB. 018  
 REZ  
 PRY  
 SGE DE  
 Y TECNICA

