

PUERTA 1	
Material	Estructural metalico - Malla Schulman
MI	0
MD	1
Total	1
Herraje	Barra antipánico - picaporte ext.
Vano	1.00m x 2.03m

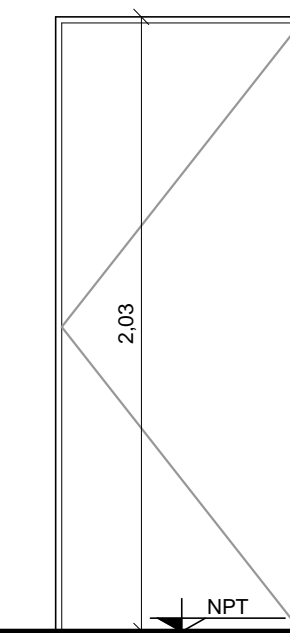

PUERTA 2	
Material	Chapa
MI	2
MD	0
Total	2
Herraje	Barra antipánico - picaporte ext.
Vano	0.90m x 2.03m

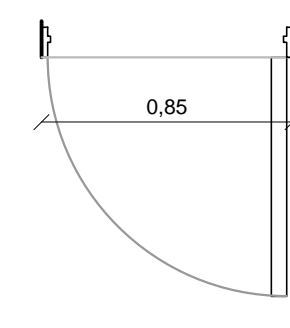
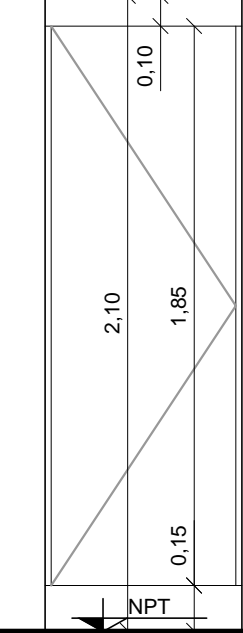
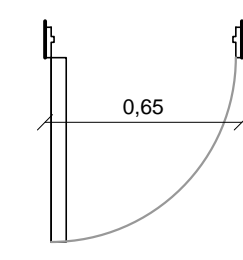

PUERTA 3	
Material	Chapa
MI	3
MD	4
Total	7
Herraje	Traba Libre / Ocupado
Vano	0.65m X 2.10m

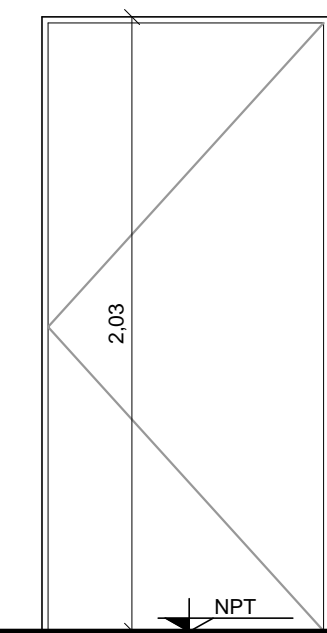
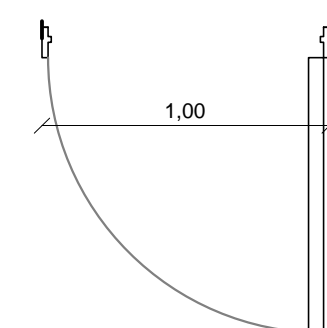

PUERTA 4	
Material	Chapa
MI	1
MD	0
Total	1
Herraje	Barra antipánico mas picaporte ext.
Vano	1.00m x 2.03m

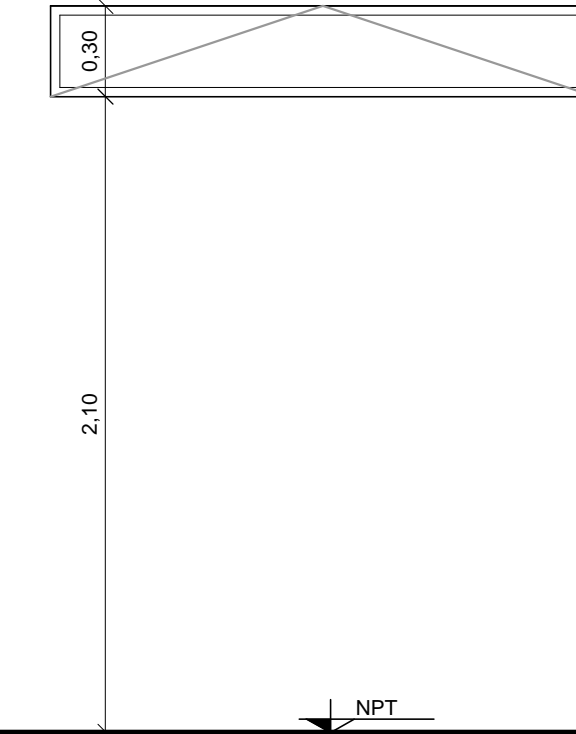
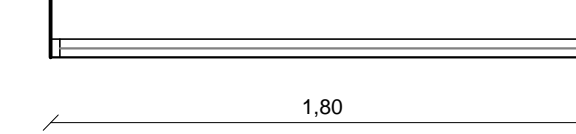

VENTANA 1	
Material	Linea Modena
Tipo	Banderola
Hojas	1
Total	4
Herraje	Falleba Metalica
Vano	1.80m x 0.30m



SUBGERENIA DE INFRAESTRUCTURA
COORD. DE OBRAS DE TERCEROS

OBRA:	REMODELACION BAÑO PUBLICO LUGANO
UBICACION:	LUGANO, C.A.B.A.
NOMBRE DE PLANO:	ANTEPROYECTO PLANILLA DE CARPINTERIAS
PLANO NO APTO PARA CONSTRUIR	

PROYECTO	ARQ. LUCIANO LAZARO
DIBUJO/MODIFICO	ARQ. LUCIANO LAZARO
REVISO	M.M.O. PUGLIESE JUAN
FECHA:	18/09/2017