

CORTE
ESC.: 1:20

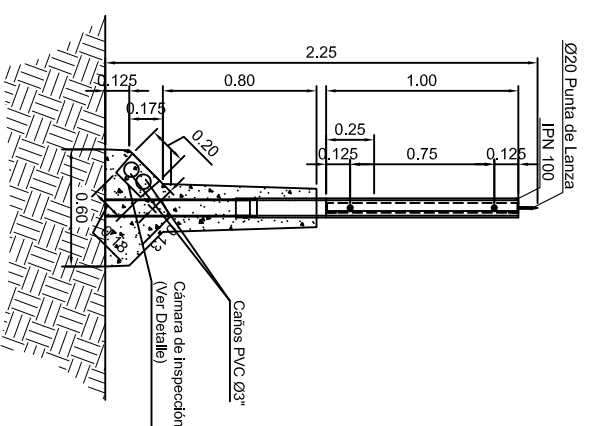

DETALLE "A"
ESC.: 1:2

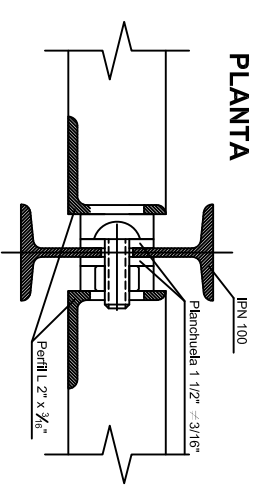
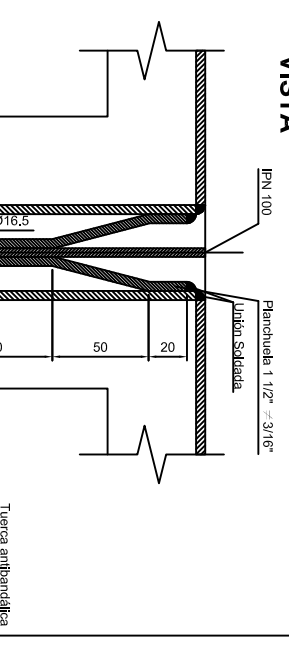

DETALLE "B"
ESC.: 1:2

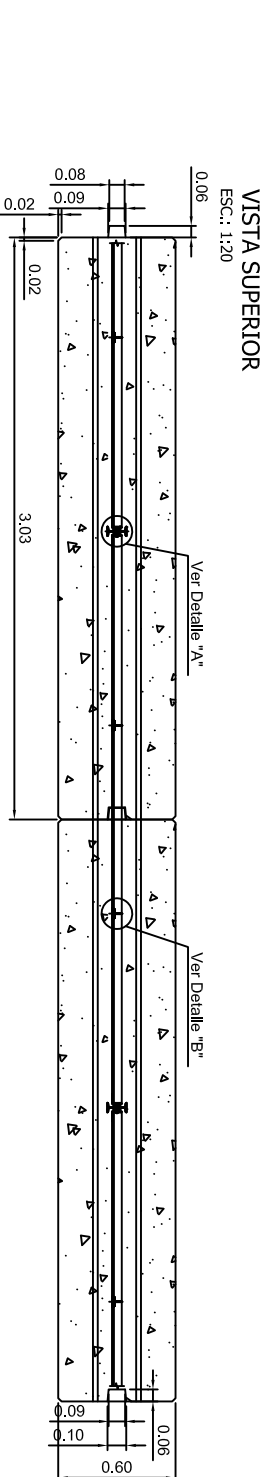
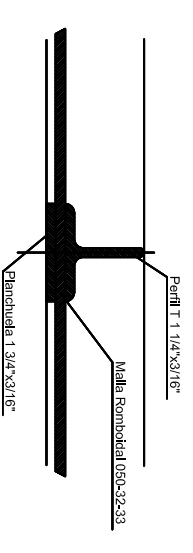

DETALLE ARMADURA
ESC.: 1:20

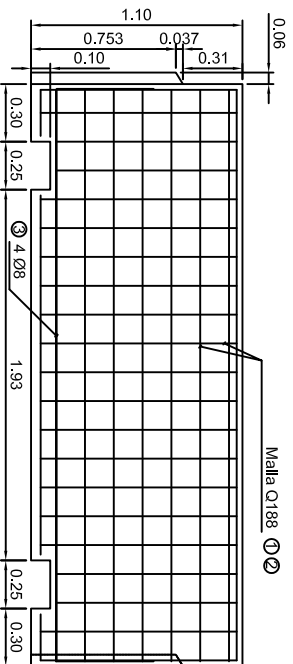

DETALLE ARMADURA
ESC.: 1:20

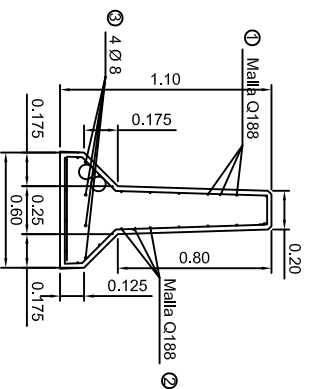

DETALLE CÁMARA DE INSPECCIÓN
ESC.: 1:5

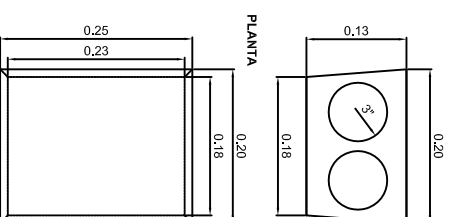

DETALLE UNIÓN E/ BLOQUES
ESC.: 1:10

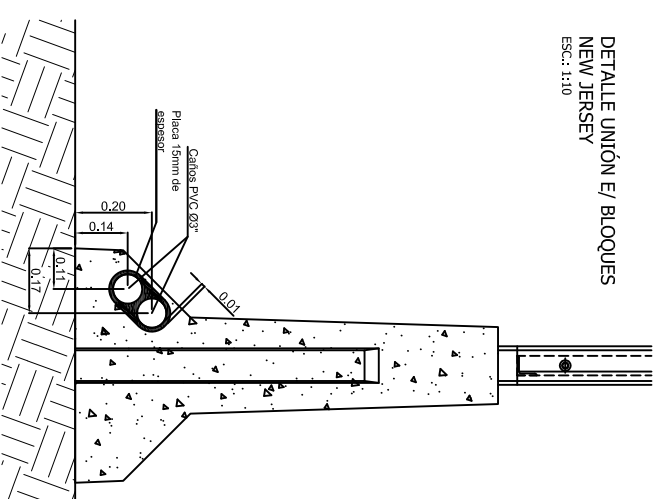

MATERIALES:
HORRIGON H17
ACERO ADN 420 (barra conformada)
ACERO AM 500 (malla electrosoldada)