

VENTANA 1	
Material	Linea Modena
Tipo	Banderola
Paños Moviles	2
Total	6
Herraje	Falleba Metalica
Vano	4.44m x 0.65m

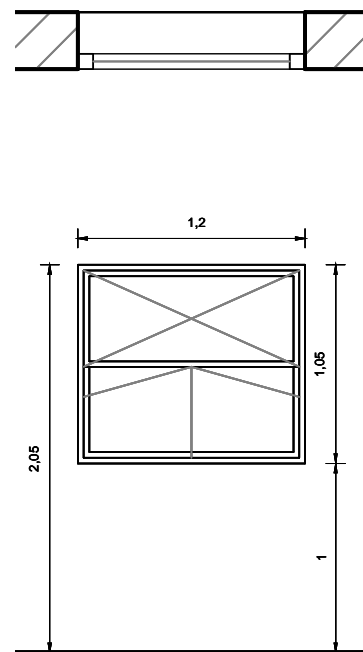

VENTANA 1	
Material	Linea Modena
Tipo	Guillotina
Paños Fijos	1
Paño Moviles	1
Total	1
Herraje	Falleba Metalica
Vano	4.44m x 0.65m

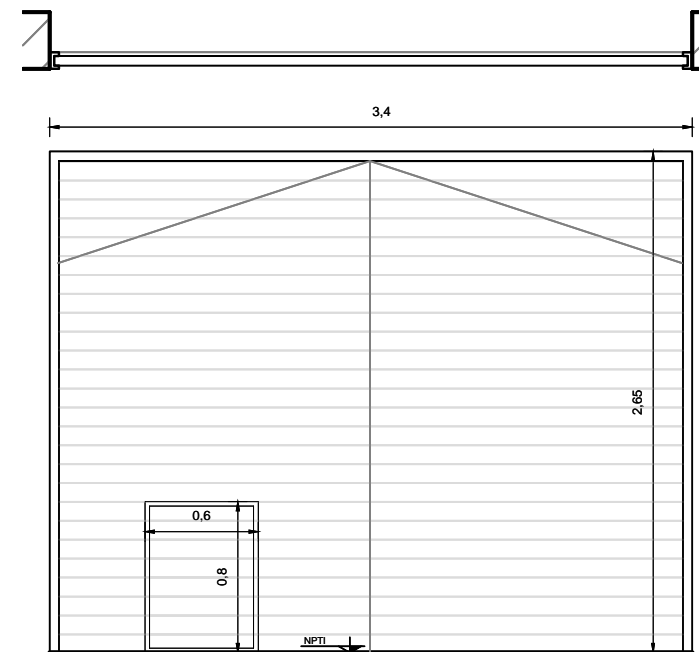

PUERTA 1	
Material	Chapa Galvanizada
Movimiento	Motor
Tipo	De Enrollar
Total	4
Vano	2.65m X 3.40m

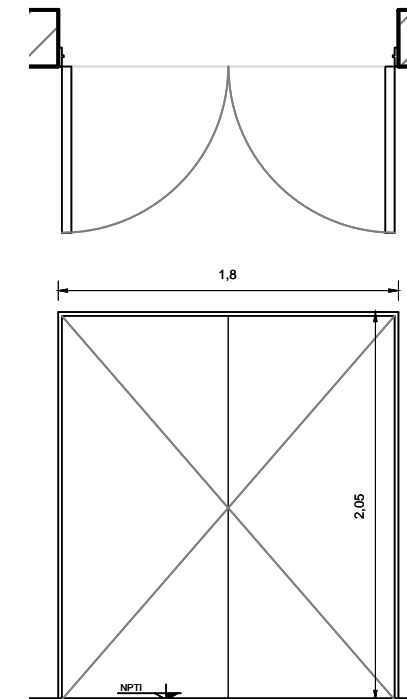

PUERTA 3	
Material	Chapa
Hojas	Doble
Total	3
Herraje	Barra antipánico mas picaporte ext.
Vano	1.80m X 2.05m

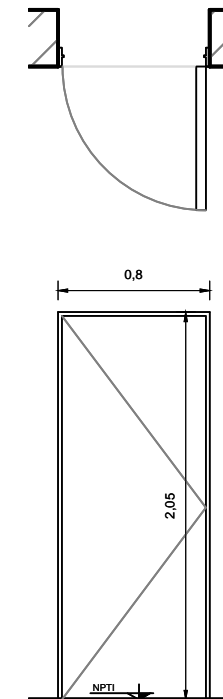

PUERTA 3	
Material	Chapa
MI	1
MD	2
Total	3
Herraje	Picaporte Interior Exterior
Vano	0.80m X 2.05m

 SUBGERENCIA DE INFRAESTRUCTURA COORD. DE OBRAS DE TERCEROS	OBRA:	AMPLIACION Y MODIFICACION DE TALLER DE SEÑALAMIENTO TAPIALES	
	UBICACION:	TAPIALES, LA MATANZA	
	NOMBRE DE PLANO:	ANTEPROYECTO CARPINTERIAS	
	PLANO NO APTO PARA CONSTRUIR	PROYECTO ARQ. LUCIANO LAZARO DIBUJO/MODIFICO M.M.O. PUGLIESE JUAN REVISO ARQ. LUCIANO LAZARO FECHA: 22/11/2017	